



**baglioni**  
pressure solutions



## CATALOGUE VESSEL

APRIL 2023  
[baglionispa.com](http://baglionispa.com)

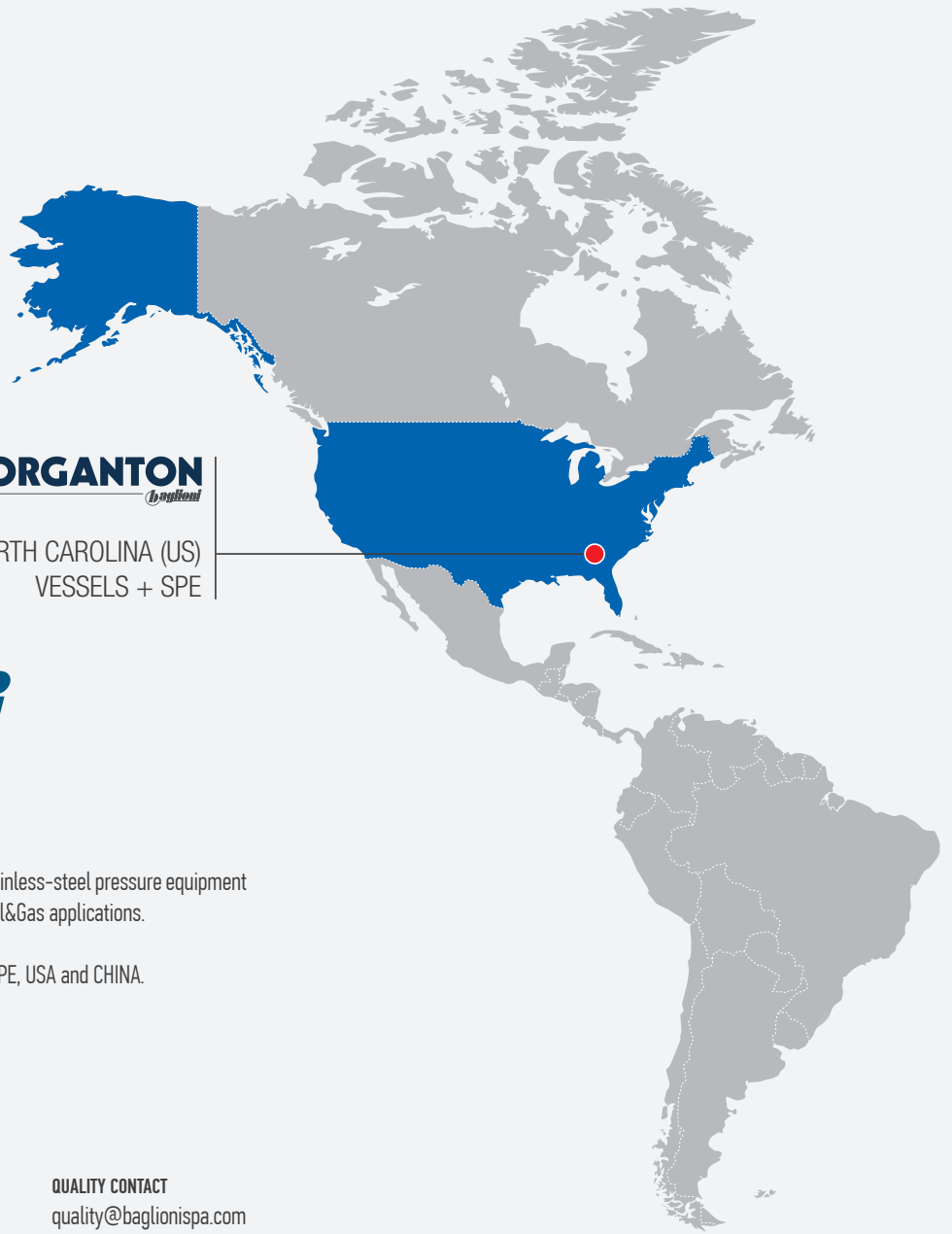

**MORGANTON**  
Baglioni

NORTH CAROLINA (US)  
VESSELS + SPE



The companies of Baglioni SpA manufacture carbon and stainless-steel pressure equipment used for storage and process in the Compressed-air and Oil&Gas applications.

Baglioni Group consists of four companies located in EUROPE, USA and CHINA.

**BAGLIONI HEADQUARTERS**

Via Dante Alighieri, 8  
28060 San Pietro Mosezzo (NO) Italy  
Tel. +39 0321485211

**SALES CONTACT**  
sales@baglionispa.com

**ENGINEERING CONTACT**  
tecnico@baglionispa.com

**QUALITY CONTACT**  
quality@baglionispa.com



**ASTRA REFRIGERANTI SRL**

ASTRA is organized into three divisions SPE, SPV and OIL & GAS. ASTRA specializes in the design and construction of tanks, heat exchangers, columns, condensers, etc. for the chemical, petrochemical and energy sectors.

**OIL & GAS**  
Via Meucci, 1  
28066 Galliate (NO) Italy  
Tel. +39 0321 808011

**AIR COM**  
**SPECIAL PRESSURE EQUIPMENT**  
Via Leopardi, 27- 28060  
San Pietro Mosezzo (NO) Italy  
Tel. +39 0321 485611

**AIR COM**  
**VESSELS**  
Via Villata, 2  
28060 Casalvolone (NO) Italy  
Tel. +39 0161 315494

**COINOX**  
**VESSELS**  
SS.16 KM 977+400  
73022 Corigliano d'Otranto (LE) Italy  
Tel. +39 0836 471239



Our C.S.C. production unit is specialized in the manufacture of pressure equipment and vacuum tanks. It manufactures certified tanks for installation sites all over the world.

**CSC SRL**  
Strada Cacciolo, 34  
15030 TERRUGGIA (AL) Italy  
Tel. +39 0142 403055



## MORGANTON

Our MPV LLC plant in Marion, North Carolina, is specialized in the manufacture of pressure vacuum tanks for medical applications as well as special pressure vessels.

### MPV MORGANTON PRESSURE VESSELS LLC SPECIAL PRESSURE EQUIPMENT

1 Alfredo Baglioni Drive  
 MARION NC 28752 USA  
 Tel. +1 (828) 6523704

## AIR COM

AIRCOM is specialized in the manufacture of pressure tanks with a capacity range from 0,9 lt and 600 lt. The main mission of our production facilities in China is to supply the Asian and Pacific markets with top-quality products at competitive prices.

### AIRCOM (ZHEJIANG) GENERAL EQUIPMENT CO. LTD

No.968 Waitang Road (Haiyan Economic Development Zone), Xitangqiao Subdistrict, Haiyan County, Jiaxing City, Zhejiang Province, China, 314305 - Tel. +86 573 86862233

# TABLE OF CONTENTS

	CERTIFICATIONS	6
	FINISHING	8
	DECLARATION OF CONFORMITY	10
	INSTRUCTIONS FOR USE AND MAINTENANCE	11
	FITNESS DECLARATION	12
<b>-10 °C AIR VESSELS</b>	<b>SMALL SIZE VERTICAL - PAINTED   GALVANIZED</b>	14
	<b>SMALL SIZE HORIZONTAL - PAINTED   GALVANIZED</b>	15
	<b>HORIZONTAL - PAINTED</b>	16
	<b>HORIZONTAL - GALVANIZED   ALM</b>	17
	<b>HORIZONTAL WITH PLATE</b>	18
	<b>VERTICAL - PAINTED 11-12-16 BAR</b>	19
	<b>VERTICAL - GALVANIZED 11-12-16 BAR</b>	20
	<b>VERTICAL -ALM 11-12-16 BAR</b>	21
	<b>VERTICAL VACUUM - PAINTED</b>	22
	<b>VERTICAL AUTOCLAVE - GALVANIZED</b>	23
<b>-20 °C AIR VESSELS</b>	<b>VERTICAL - PAINTED 11-12-16 BAR -20 °C</b>	25
	<b>VERTICAL - GALVANIZED   ALM -20 °C</b>	26
	<b>VERTICAL FOR OXYGEN</b>	27
	<b>VERTICAL OVERSIZE - PAINTED</b>	28
	<b>VERTICAL OVERSIZE - GALVANIZED   ALM</b>	29
	<b>HORIZONTAL OVERSIZE - PAINTED   GALVANIZED   ALM</b>	30
	<b>FLANGED CONNECTIONS AND NON-MANDATORY INSPECTION OPENINGS</b>	31
<b>HIGH PRESSURE VESSELS</b>	<b>VERTICAL 21 BAR - PAINTED   GALVANIZED</b>	33
	<b>VERTICAL 32 BAR - PAINTED   GALVANIZED</b>	34
	<b>VERTICAL 42 BAR - PAINTED   GALVANIZED</b>	35
	<b>ASME</b>	36
<b>STAINLESS STEEL VESSELS</b>	<b>VERTICAL - AISI 304   AISI 316L</b>	38
	<b>HORIZONTAL - AISI 304   AISI 316L</b>	39
	ACCESSORIES	40
	SPECIAL PROJECTS	42

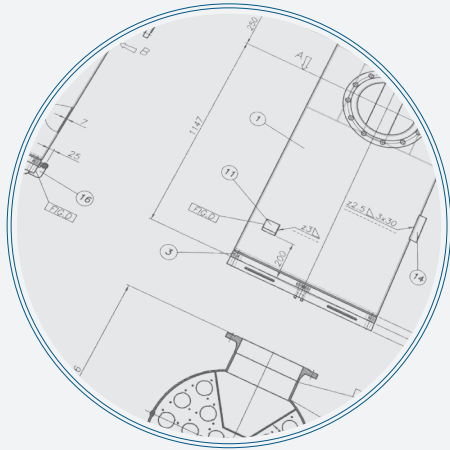

## CO-DESIGN

Innovative solutions and our know-how are at the customer's disposal to develop a design that aims to optimize the product on an industrial scale and to obtain the best technical and economical results.



## GLOBAL DESIGN

Our engineering develops the projects and adapts them to the in force regulations on an international scale to keep the same standard of production for all factories in the three continents.



## LOCAL PRODUCTION

Our main goal is to minimize both production and transport costs by producing locally and covering the whole range of products, from standard to custom made.



## MULTI APPROVAL

According to geographical areas and customer's specification we design products in compliance with dedicated approvals and, if necessary, simultaneous certifications.



## FINISHING

The knowledge of materials and their employment in various applications allows us to offer a wide range of finishing, an important added value for the customization of products.



## CUSTOMIZED LOGISTICS

Flexibility to adapt to customer's needs through the management of specific logistics according to the product type.

# CERTIFICATIONS

Our products are designed and manufactured in compliance with the applicable EU Directives or according to the major international standards.

**CERTIFICATO**  
 Nr 50 100 6900 - Rev. 03  
 AIR COM S.r.l.  
 UNI EN ISO 9001:2008  
 Progettazione e fabbricazione di fondi, scambiatori, raffreddatori, filtri, separatori, ventole in pressione, tubazioni e impianti speciali (per 18, 17)  
 Design and manufacture of heads, heat exchangers, coolers, filters, separators, pressure vessels, piping and special plants (per 18, 17)

**THE NATIONAL BOARD OF BOILER & PRESSURE VESSEL INSPECTORS**  
 Certificate of Authorization  
 AIR COM S.R.L. ASP  
 Via D. Alighieri No 8  
 S. Pietro Mesezzo (NOVARA), 29060 ITALY  
 Issued Date: May 26, 2014  
 Expiration Date: April 18, 2017

**CERTIFICATE OF AUTHORIZATION**  
 U1  
 COMPANY: AIR COM S.R.L. ASP  
 Via Leopardi N. 27  
 S. Pietro Mesezzo 29060 Italy  
 SCOPE: Manufacture of miniature pressure vessels at the above location only  
 AUTHORIZED: April 15, 2014  
 EXPIRES: June 3, 2016  
 CERTIFICATE NUMBER: 35,138

**CERTIFICATO**  
 Garanzia Qualità Produzione (Modulo D)  
 CE 1131  
 C.E.C. s.r.l.  
 Strada Cavallotti, n. 34  
 10058 Torreggione (NO)  
 CONSORZIO EUROPEO CERTIFICAZIONE L'ORGANO DELIBERANTE

**中华人民共和国特种设备制造许可证**  
 Manufacture License of Special Equipment  
 People's Republic of China  
 (压力容器) (Pressure Vessel)  
 No.: TS2200147-2018  
 公司/Company: AIR COM S.r.l.  
 地址/Address: Via Leopardi, 27-28060 San Pietro Mesezzo (NO), ITALY  
 经审查, 获准从事下列压力容器的制造:  
 Has been audited and approved to manufacture the Pressure Vessels within the scope as:  
 压力容器 D1、D2 / Pressure Vessels D1, D2  
 有效期至: 2018年06月21日  
 Date of Expiration: Jun.21, 2018

**CERTIFICATE OF AUTHORIZATION**  
 U2  
 COMPANY: AIR COM S.R.L. ASP  
 Via D. Alighieri No 8  
 S. Pietro Mesezzo (NOVARA) 29060 Italy  
 SCOPE: Manufacture of pressure vessels at the above location only  
 AUTHORIZED: April 18, 2014  
 EXPIRES: April 18, 2017  
 CERTIFICATE NUMBER: 49,142



---

SPVD 2014/29/UE DIRECTIVE (EX 2009/105/EC)  
Simple Pressure Vessels Directive

---

ASME SECT. VIII DIV. 1 / DIV. 2

---

CANADIAN REGISTRATION NUMBER (CRN)

---

MOM SINGAPORE REGULATION

---

CONSULAR VISA  
TUNISIA - MOROCCO

---

MHLW JAPAN REGULATION

---

MARINE REGISTRATION

- ABS American Bureau of Shipping
- DNV Det Norske Veritas
- B.V. Bureau Veritas
- LRS Lloyd's Register of Naval Ship
- RINA Services
- GL Germanischer Lloyd
- NK Nippon Kaiji Kyokai
- CCS China Classification Society
- RMRS Russian Maritime Register of Shipping
- KR Korean Register of Shipping

---

PED 2014/68/UE DIRECTIVE (EX 97 /23/EC)  
Pressure Equipment Directive

---

NATIONAL BOARD REGISTRATION

---

AUSTRALIAN STANDARD AS1210

---

DOSH MALESIA REGULATION

---

MANUFACTURE LICENSE OF SPECIAL EQUIPMENT  
People's Republic of China D1/D2 - A1/ A2

---

ISRAELIAN STANDARD REGULATION

---

EAC TRCU032 RUSSIA

---

UKCA (UK CONFORMITY ASSESSED) MARKING

---

## POWDER COATING

External surface treatment performed on all standard vessels.

After an accurate surface preparation through chemical wash-down or sandblasting, the product is transferred to dedicated booths where powder paint is sprayed by means of electrostatic or triboelectric spray guns. The processed product is then baked in curing ovens.

---

## HOT-DIP GALVANIZATION

Internal and external treatment for carbon steel vessels.

Hot-dip galvanizing is the main method used to protect steel against weather conditions and is performed by dipping vessels in a molten zinc bath. During this metallurgical process, the surface composition changes into an intercrystalline zincsteel alloy that forms an extremely resistant, longlasting anti-corrosion coating. The thickness of the protection depends on material type, dipping time and zinc bath temperature.

---

## SURFACE ELECTROPOLISHING TREATMENT

This surface treatment electrolytically removes all metal particles in order to reduce roughness. for carbon steel vessels.

This process is essential when corrosion-resistance and cleanliness requirements are particularly strict (e.g., for pharmaceutical, chemical, biochemical and food products).

---

## ALM PAINTING

This treatment is specific for tank interiors and is performed by applying special protective paints that ensure high resistance to corrosive agents over time.

Raw vessels first undergo chemical washing and pickling and are then sprayed with thermosetting epoxy resin before completing the process with the final baking stage in the oven. The ALM treatment is certified pursuant to Ministerial Decree dated 21 March 1973 and subsequent amendment dated 6 April 2004.

---

## PICKLING AND PASSIVATION

Internal and external treatment of stainless steel vessels. for carbon steel vessels.

Pickling is essential to remove the oxide particles produced during the various processing stages. There are two types of pickling systems: mechanical and chemical. The former is performed with silica sand or stainless-steel brushes, the latter by dipping the item into an acid solution. The subsequent passivation dissolves and removes any contaminants from the surface, thus recreating the protective layer.





RAL 1004  
Smooth Finish



RAL 3000  
Smooth Textured Finish



RAL 5002  
Smooth Finish



RAL 5005  
Textured Finish



RAL 5010  
Smooth Finish



RAL 5015  
Smooth Textured Finish



RAL 7011  
Textured Finish



RAL 7016  
Smooth Textured Finish



RAL 7021  
Smooth Textured Finish



RAL 7024  
Textured Finish



RAL 7035  
Textured Finish



RAL 7036  
Textured Finish



RAL 7040  
Textured Finish



RAL 7042  
Textured Finish



RAL 7043  
Smooth Finish



RAL 9002  
Textured Finish

# DECLARATION OF CONFORMITY

All pressure vessels for the European market are supplied with a declaration of conformity bearing all vessel identification data.  
This certificate shall be duly kept to be submitted to inspection authorities during periodical audits as specified by the applicable regulations.

FOR INQUIRIES CONCERNING DECLARATION OF CONFORMITY PLEASE CONTACT  
quality@baglionispa.com



## DICHIARAZIONE DI CONFORMITÀ

DECLARATION DE CONFORMITE

DECLARACIÓN DE CONFORMIDAD

DECLARATION OF CONFORMITY

KONFORMITÄTSEKTLÄRUNG

• Dichiariamo, sotto la nostra responsabilità, che il serbatoio nuovo qui descritto:  
*Nous déclarons, sous notre seule responsabilité, que le récipient neuf décrit ci après:*  
We hereby declare under our own responsibility, that the pressure vessel described hereunder:  
*Declaramos, bajo nuestra unica responsabilidad, que el recipiente nuevo descrito aqui:*  
Unter unserer Verantwortung erklären wir hiermit, daß der neue unten beschriebene Druckluftbehälter:

N.F.:	Capacità:	LOTTO N.:	Anno di fabbricazione:
N.F.:	Volume:	LOT N.:	Année de fabrication:
Manufacturing N.:	Capacity:	Lot inspection:	Year of construction:
Matricula N.:	Capacidad:	Lote N.:	Año de fabricación:
Bau-Nr.:	Inhalt:	Losprüfung:	Baujahr:
De 9491	Lt. 500	03/09	2009
À 9526			
Famiglia:	Pressione di servizio/Calcolo:	Variante:	Temperatura di servizio:
Famille:	Pression de service/Calcul:	Variante:	Temperature de service:
Family:	Operating pressure/Calculation	Type:	Operating temperature:
Familia:	Presión de servicio/Calculo:	Variacion:	Temperatura de servicio:
Familie:	Betriebsüberdruck/Berechnungsdru	Typ:	Betriebstemperatur:
EC	bar 16	EC500.16	-10°C +120°C

È CONFORME ALLE DISPOSIZIONI DELLA DIRETTIVA CEE 87/404 RELATIVA AI RECIPIENTI SEMPLICI A PRESSIONE  
*EST CONFORME A LA DIRECTIVE 87/404 CEE RELATIVE AUX RECIPIENTES A PRESSION SIMPLES*  
COMPLIES WITH ECC DIRECTIVE 87/404 CONCERNING SIMPLE PRESSURE VESSELS  
*ES CONFORME A LAS DISPOSICIONES DE LA NORMATIVA CEE 87/404 RELATIVA A LOS RECIPIENTES A PRESTION SIMPLES*  
DEN VORSCHRIFTEN EG-RICHTLINIE 87/404 ÜBER EINFACHE DRUCKBEHÄLTER ENTSpricht

• che al modello della famiglia e sue varianti alla quale questo serbatoio appartiene è stata riconosciuta una:  
*que le modèle de la famille et ses variantes à laquelle appartient ce récipient a fait l'objet de la délivrance d'une:*  
that the family type and its variations, which this vessel is part of, has received:  
*que el modelo de la familia y sus tipos al que pertenece este recipiente ha sido el objeto de la deliberacion de una:*  
daß der betreffende Behältertyp mit:

ATTESTAZIONE D'ESAME DEL TIPO N. 07.72226/C/PS DEL 18/10/07 REV. 18/10/07 rilasciata da CPM, organismo notificato n°I-0398  
*ATTESTATION D'EXAMEN CE DE TYPE N° 07.72226/C/PS DU 18/10/07 M.J. 18/10/07 délivrée par la CPM, organisme notifié n°I-0398*  
ECC TYPE EXAMINATION CERTIFICATE N° 07.72226/C/PS DATED 18/10/07 REV. 18/10/07 issued by CPM, official test body n°I-0398  
*CERTIFICACION DE EXAMEN CE DE TIPO N° 07.72226/C/PS DEL 18/10/07 REV. 18/10/07 expedido por CPM, organismo notificado n°I-0398*  
EG-BAUMUSTERPRÜFUNG NR. 07.72226/C/PS VOM 18/10/07 REV. 18/10/07 von anerkannter Prüfstelle CPM, n°I-0398 geprüft wurde

• che questo serbatoio ha superato una prova idraulica a una Pressione di Prova uguale a 1,5 volte la pressione di calcolo.  
*que ce récipient a subi avec succès un essai hydraulique à une Pression d'Épreuve égale à 1,5 fois la Pression de calcul.*  
that the aforementioned pressure vessel passed the hydraulic test when submitted to a test pressure equal to 1,5 times the design pressure.  
*que este recipiente ha superado con seguridad una prueba hidráulica a una presión igual a 1,5 veces la presión de cálculo.*  
daß obiger Behälter die Wasserdruckprobe bestanden hat, wobei der Proberdruck 1,5 mal der Nenndruck entsprach.

• che l'Organismo notificato ha apposto una punzonatura di identificazione (cuore APAVE) sulla targa del costruttore.  
*que l'Organisme notifié a apposé un poinçon identification (coeur APAVE) sur la plaque constructeur.*  
that the notified institution has applied a marking punch on the name plate.  
*que el Organismo notificado ha puesto una marca de identificación (corazon APAVE) sobre la placa constructor.*  
daß die anerkannte Prüfstelle einen Kennzeichnungstempel auf das Herstellerschild gestempelt hat.

Terruggia, il 2/7/2009

Il Costruttore – Le Constructeur – The Manufacturer  
El constructor – Der Hersteller

\*CSC099491-9526\*



Pagina 1 di 2

# INSTRUCTIONS FOR USE AND MAINTENANCE

Instructions for a proper use and maintenance of the vessels are found on page 2 of the Dec. of conf. A strict attention of this instructions will ensure the lifespan and safe use of the vessels. The parameters displayed at the bottom of this sheet are of the utmost importance to this purpose:

- Rating (A): refers to design pressure (bar) as well as the pressure limit for vessel use. This rate is found both on the name plate and the Declaration of Conformity.
- Rating (B): refers to shell thickness (mm) below which the vessel can no longer be kept in operation
- Rating (C): refers to formed heads thickness (mm) below which the vessel can no longer be kept in operation

It is extremely important that ratings (B) and (C) are tested regularly because water, gas or bacterial reactions may cause natural corrosion phenomena which will determine the deterioration of materials and eventually jeopardize the product's performance.

**NOTICES D'INSTRUCTION**

Le récipient à pression est destiné à l'accumulation d'air comprimé et ne doit pas être soumis à de rapides fluctuations de pression. L'utilisation adéquate de l'appareil à air comprimé est une condition préalable essentielle pour en garantir la sécurité. Dans ce but l'utilisateur doit:

- 1) employer l'appareil de façon appropriée dans les limites établies de pression et de température de service qui sont indiquées sur la plaque du Constructeur.
- 2) éviter d'effectuer des soudures sur les parties à pression;
- 3) vérifier que l'appareil soit équipé d'organes de sécurité (soupape de sécurité et pressostat) et de contrôle (manomètre) efficaces et suffisants et veiller à leur remplacement, en cas de nécessité, par d'autres organes ayant des caractéristiques équivalentes, après en avoir informé le Constructeur. En particulier, la soupape de sécurité doit être appliquée directement sur le réservoir sans possibilité d'interposition, doit avoir une capacité de décharge supérieure à la quantité d'air qui peut être admise dans le réservoir, être tarée et plombée à la pression de (A) bar. Sur le manomètre, l'index de pression de (A) bar doit être indiqué par un trait rouge.
- 4) éviter autant que possible de placer l'appareil dans des locaux qui ne sont pas suffisamment aérés; éviter scrupuleusement d'installer l'appareil dans des zones exposées à des sources de chaleur ou à proximité de substances inflammables.
- 5) équiper impérativement l'appareil de liaisons élastiques sur les supports inférieurs et lorsque soit le modèle (fixe ou mobile) pendant son utilisation de façon à éviter des vibrations qui pourraient provoquer des ruptures ou fatigues. Ne pas fixer le récipient ou des parties mobiles sur le récipient ni au sol ou sur des parties fixes (colonnes, ...).
- 6) Prévenir la corrosion: selon le mode d'emploi, des condensats peuvent s'accumuler dans les réservoirs, ceux-ci doivent être purgés tous les jours. Cela peut se faire manuellement en ouvrant la purge de condensat ou par un purgeur automatique monté sur le réservoir. Dans le cadre de la maintenance l'utilisateur, ou le service après vente habilité, doit vérifier la formation éventuelle de corrosion à l'intérieur et effectuer un contrôle extérieur à intervalles annuels. Si le réservoir est utilisé avec un compresseur sec, dans une ambiance fortement humide, ou dans des conditions défavorables (faible ventilation, vapeur acide ...) le contrôle visuel doit se faire plus fréquemment. L'épaisseur effective du réservoir après corrosion ne devra pas être inférieure à (B) mm pour la virole et (C) mm pour les fonds.
- 7) agir en tout cas avec bon sens et pondération de manière analogue aux cas prévus.

**TOUTE MANIPULATION ET UTILISATION IMPROPRE DE L'APPAREIL SONT FORMELLEMENT INTERDITES.**

Rappel à l'utilisateur que dans tous les cas, il est tenu de respecter la législation sur l'utilisation des appareils à pression du Pays ou il en fait usage.

**INSTRUCTION FOR USE OF COMPRESSED AIR VESSEL**

The pressure vessel is intended to be used for storage of compressed air and shall not be subject to rapid fluctuation of pressure. To ensure operation of compressed air vessel under safe conditions, the proper use of same must be guaranteed.

To this purpose, the user should proceed as follows:

- 1) use the vessel properly, within the pressure and temperature limits stated on the nameplate and on the testing report, which must be kept with care;
- 2) welding on the vessel is forbidden;
- 3) ensure that the vessel is complete with suitable and adequate safety and control fittings and replace them with equivalent ones in case of necessity, prior to the Manufacturer's consent. In particular, the safety valve must be applied directly to the vessel, have a discharge capacity higher than the air intake and be set and loaded at a pressure of (A) bar. The pressure value of (A) bar on the pressure gauge should be indicated with a red mark;
- 4) avoid, if it is possible, to store the vessel in badly ventilated rooms. Avoid scrupulously to store the vessel near heating sources or inflammable substances;
- 5) Fit the pressure vessel with vibration dampers to avoid possible fatigue failure caused by vibration of the vessel during use. Don't anchor the vessel or attached components to the ground or fixed structures (columns etc).
- 6) Corrosion must be prevented: depending on the conditions of use, condensation may accumulate inside the tank, and this must be emptied out every day. This may be done manually, by opening the draining tap, or by means of the automatic condensation drainer, if fitted to the tank. During maintenance, every 12 months, the user or a Client Service expert must check the presence of internal corrosion and perform an external visual control. If the receiver is used with an oil-free compressor, or in surroundings that have a high level of humidity, or in adverse conditions (poor ventilation, corrosive agents, ...), the inspections should be made more frequently. The actual wall thickness of the tank after corrosion should not be smaller than (B) mm for the shell and (C) mm for the heads.
- 7) The legal checks have to be made in accordance with the local laws and rules where the receiver is used.

7) proceed sensibly and carefully, according to the existing prescriptions.

**TAMPERING AND IMPROPER USE OF THE TANK ARE FORBIDDEN**

The users must comply with the laws on the operation of pressure equipment in force in the relative countries.

**BETRIEBSANWEISUNGEN**

Der Behälter ist bestimmt zur Speicherung von Druckluft; seine Auslegung erfolgte für überwiegend statischen Betrieb. Die korrekte Bedienung des Druckluftbehälters ist eine unabdingbare Voraussetzung, um die Sicherheit zu gewährleisten. Zu diesem Zweck sollte der Anwender wie folgt vorgehen:

- 1) den Druckluftbehälter innerhalb der Nenn-Druck- und Temperaturgrenzen verwenden, die auf dem Schild und in der Konformitätserklärung angegeben sind, die mit der größten Sorgfalt zu bewahren ist;
- 2) keine Schweißarbeiten auf drucktragenden Teilen durchführen;
- 3) sich vergewissern, dass der Behälter mit dem entsprechenden Sicherheits- und Prüfzubehör ausgestattet ist, das in Notfall durch gleichwertige Ausrüstung nach Rücksprache mit dem Hersteller zu ersetzen ist. Insbesondere muss die Sicherheitsventil unmittelbar auf den Behälter angebracht werden, eine höhere Ablasekapazität als der Lufteinlass haben und auf einen Druck von (A) bar geeicht und plombiert werden. Auf dem Druckmesser muss der Druckwert von (A) bar in Rot gekennzeichnet sein;
- 4) möglichst vermeiden, dass der Druckluftbehälter in schlecht belüfteten Räumen aufgestellt wird; sorgfältig vermeiden, dass der Behälter Wärmequellen oder entflammenden Stoffen ausgesetzt wird;
- 5) Der Behälter ist mit Vibrationsdämpfern auszustatten, um zu vermeiden, dass der Behälter Betriebsvibrationen ausgesetzt wird, die Dauerbrüche verursachen können; der Behälter oder an ihm montierte Teile dürfen nicht am Boden oder an feststehenden Teilen (Pfählen ...) befestigt werden.
- 6) Vorbeugung gegen Korrosion: Je nach Betriebsbedingungen kann sich im Behälter Kondensat ansammeln, das täglich abgelassen werden muss. Dies kann entweder manuell durch Öffnen des Ablaufventils oder durch einen angelaubten/automatischen Kondensatablasser erfolgen. Im Rahmen der Wartung muß der Behälter einer regelmäßigen, jährlichen Kontrolle auf innere Korrosion durch den Betreiber oder den zuständigen Kundendienst und einer externen Sichtprüfung unterzogen werden. Beim Betrieb des Behälters mit einem ölfreien Kompressor, bei hoher Luftfeuchtigkeit oder ungünstigen Betriebsbedingungen (wenig Frischluft, Säuredämpfe o.ä.) sollte die Sichtprüfung in geringeren Zeitabständen erfolgen. Die tatsächliche Wandstärke des korrodierten Behälters darf auf keinen Fall (B) mm am Mantel und (C) mm an den Böden unterschritten werden. Die gesetzlich vorgeschriebenen Prüfungen müssen gemäß der geltenden Gesetze des Landes organisiert werden, in dem der Behälter verwendet wird.
- 7) bei der Montage und Inbetriebnahme des Behälters prüfen, dass Betriebssicherheit gewährleistet ist.

**MUTWILLIGE BESCHÄDIGUNGEN UND MIßBRAUCH DES BEHÄLTERS SIND VERBOTEN.**

Die Anwender werden darauf hingewiesen, die im jeweiligen Land gültigen Gesetzesvorschriften über den Betrieb der Druckbehälter zu befolgen.

**ISTRUZIONI D'USO**

Il serbatoio a pressione è destinato all'accumulo di aria compressa ed è calcolato per utilizzo principalmente statico. Un suo corretto utilizzo è premessa indispensabile per garantirne la sicurezza.

A tale scopo l'utilizzatore deve ma non solo:

- 1) utilizzare correttamente il serbatoio nei limiti di pressione e di temperatura di progetto che sono riportati sulla targa del Costruttore e sulla dichiarazione di conformità che deve essere conservata con cura;
- 2) evitare di effettuare saldature sulle parti esposte a pressione.
- 3) garantire che il serbatoio sia sempre completo di efficienti accessori di sicurezza e di controllo e provvedere in caso di necessità alla loro sostituzione con altri di equivalenti caratteristiche, sentito in merito il Costruttore. In particolare, la valvola di sicurezza deve essere applicata direttamente sul recipiente senza possibilità di interposizione, deve avere una capacità di scarico superiore alla quantità di aria che può essere immessa nel recipiente, essere tarata e plombata alla pressione di (A) bar. Sul manometro, l'indice di pressione di (A) bar deve essere indicato con un segno rosso;
- 4) evitare se possibile di utilizzare il serbatoio in locali non sufficientemente areati; evitare scrupolosamente di collocare il serbatoio in zone esposte a sorgenti di calore o nelle vicinanze di sostanze infiammabili;
- 5) munire il serbatoio di anti-vibranti in modo da evitare che il serbatoio durante l'esercizio sia soggetto a vibrazioni che possono generare rotture per fatica; non bloccare al suolo o a parti fisse (colonne, ...) il serbatoio o parti ad esso montate.
- 6) Prevenire la corrosione: a seconda delle condizioni d'impiego, si può accumulare all'interno del serbatoio della condensa che deve essere scaricata quotidianamente. Ciò può essere fatto manualmente aprendo il rubinetto di scarico attraverso lo scaricatore di condensa automatico montato sul serbatoio. Nell'ambito della manutenzione, annualmente l'utilizzatore o un esperto del servizio assistenza deve verificare l'assenza di eventuale corrosione interna nel serbatoio ed effettuare un controllo visuale esterno. Se il recipiente è utilizzato con compressore oilfree o in ambienti che presentano un alto tasso di umidità o condizioni di impiego sfavorevoli (scarsa ventilazione, agenti corrosivi, ...) i controlli devono essere eseguiti ad intervalli più ravvicinati. Lo spessore effettivo del recipiente dopo corrosione non dovrà essere inferiore a mm. (B) per il mantello e mm (C) per il fondo. I controlli legalmente richiesti devono essere organizzati secondo le leggi e le norme del Paese dove il serbatoio è utilizzato.
- 7) Agire in ogni caso con senno e ponderatezza in analogia ai casi previsti.

**E' TASSATIVAMENTE VIETATA LA MANIPOLAZIONE DEL SERBATOIO E OGNI UTILIZZAZIONE IMPROPRIA.**

Si rammenta all'utilizzatore che è comunque tenuto a rispettare le leggi sull'esercizio degli apparecchi a pressione in vigore nel Paese di utilizzo.

I serbatoi con P x V maggiore uguale a 8.000 bar per litro o pressione maggiore di 12 bar sono soggetti alle verifiche di primo impianto e alle visite periodiche da parte dell'ente preposto così come definito nel D.M. 329 del 01.12.2004

**INSTRUCCIONES PARA EL USO**

El depósito de aire comprimido sirve para acumular el aire comprimido y no debe someterse a rápidas variaciones de presión. La condición indispensable para garantizar la seguridad es la utilización correcta del depósito a presión de aire comprimido. Para ello el usuario deberá observar las siguientes reglas:

- 1) utilizar de forma correcta el depósito teniendo en cuenta los límites de presión y temperatura para los que ha sido diseñado, valores que aparecen indicados en la placa del Constructor y en el documento de conformidad que debe ser cuidadosamente guardado;
- 2) no efectuar soldaduras en las piezas a presión;
- 3) cercionarse de que el depósito siempre vaya provisto de eficientes y suficientes accesorios de seguridad y control y en caso necesario substituirlos con otros de características equivalentes, tras conformidad del Constructor. En concreto, la válvula de seguridad debe ser aplicada directamente en el recipiente sin posibilidad de interposición, debe tener una capacidad de descarga superior a la cantidad de aire que puede ser introducida y debe ser calibrada y sellada a la presión de (A) bar. En el manómetro el índice de presión de (A) bar debe estar indicado por una señal de color rojo;
- 4) - si es posible, no colocar el depósito en locales no suficientemente ventilados; - no colocar nunca el depósito en zonas expuestas a fuentes de calor o cerca de sustancias inflamables;
- 5) Instalar antivibraciones en el depósito para evitar que durante su uso esté sujeto a vibraciones que pueden provocar roturas por desgaste; no fijar el depósito ni piezas que tenga montadas al suelo ni a elementos fijos (columnas, etc.).
- 6) Prevenir la corrosión: dependiendo de las condiciones de uso, en el interior del depósito puede acumularse condensación que debe descargarse diariamente. Esta operación debe realizarse manualmente abriendo la llave de descarga o a través del descargador automático de condensación montado en el depósito. Referente a la manutención, el usuario o un técnico del servicio debe comprobar anualmente si hay formación de corrosiones en el interior del depósito e inspeccionar el exterior. Si el recipiente se utiliza con compresores en seco o en lugares con un alto índice de humedad, o en condiciones de uso desfavorables (poca ventilación, agentes corrosivos, ...) los controles deberán realizarse con mayor frecuencia. De todas formas el espesor efectivo del recipiente tras la corrosión no deberá ser inferior a los (B) mm en la capa cilíndrica y los (C) mm en el fondo. Los controles legalmente deberán llevarse a cabo de acuerdo con las leyes y normas vigentes en el país donde se utilice el depósito.
- 7) actuar siempre con racionalidad y ponderación teniendo en cuenta los casos previstos.

**ESTA TÁXATIVAMENTE PROHIBIDA LA MANIPOLACION DEL DEPOSITO Y TODA UTILIZACION INADECUADA.**

Se recuerda que el usuario debe responder de las leyes de utilización de las máquinas de presión vigentes en el País en el que se utilizan.

**EXHIBIT ONLY - NOT USABLE**

(A) = 16      (B) = 4,45      (C) = 4,05      familia EC      N.F.      dal 9491      al 9526

Pagina 2 di 2

DESIGN PRESSURE

MINIMUM SHELL THICKNESS (CYLINDER BODY)

MINIMUM HEADS THICKNESS

# FITNESS DECLARATION

The vessels are not included in the range of applicability of the 2014/68/UE directive, because they are not equipped with any source of ignition. Upon request, can be supplied the Fitness Declaration Atex.



## DICHIARAZIONE DI IDONEITÀ - DIRETTIVA 2014/34/UE FITNESS DECLARATION - DIRECTIVE 2014/34/UE (EN 45014:1999)

In riferimento a:

Art.1, par. 2, della direttiva 2014/34/UE, dtd. 26 febbraio 2014,

Capitoli 37 e 40 delle ATEX 2014/34/UE Guidelines 2nd Edition, dtd. Dicembre 2017

Sulla base dell'analisi dei rischi effettuata, l'attrezzatura: VECO1251 serbatoio 50lt 11bar

### **NON RIENTRA NEL CAMPO DI APPLICAZIONE DELLA DIRETTIVA 2014/34/UE**

in quanto non possiede al suo interno ed al suo esterno nessuna sorgente di innesco propria.

Per questo motivo non è soggetta a nessuna valutazione e a nessuna marcatura come previsto dalla direttiva.

*In accordance with:*

*Art.1, par. 2, of Directive 2014/34 / EU, dtd. 26 February 2014,*

*Chapters 37 and 40 of ATEX 2014/34/UE Guidelines 2nd Edition, dtd. December 2017*

*Based on the risk analysis carried out, the equipment: VECO1251 Vessel 50lt 11bar*

### **IS NOT INCLUDED IN THE RANGE OF APPLICABILITY OF THE 2014/34 /EU DIRECTIVE**

*because it does not has an own source of ignition.*

*For this reason, it is not subject to any evaluation or marking as required by the directive.*

09/07/2020  
Casalvolone (Novara)



**-10°C AIR VESSELS**

-10°C AIR VESSELS

# SMALL SIZE VERTICAL PAINTED - GALVANIZED

## MATERIAL

Carbon steel

## FLUID CONTENT

Compressed air / Nitrogen (group 2)

## FINISHING

**RAL5015:** External Ral 5015 blue paint (standard)

**GALVANIZED:** internal and external hot-dip galvanization

## UPON REQUEST

1" couplings on heads

DIRECTIVE

2014/29/UE

OPERATING PRESSURE

11/16 bar

OPERATING TEMPERATURE

-10 +120°C

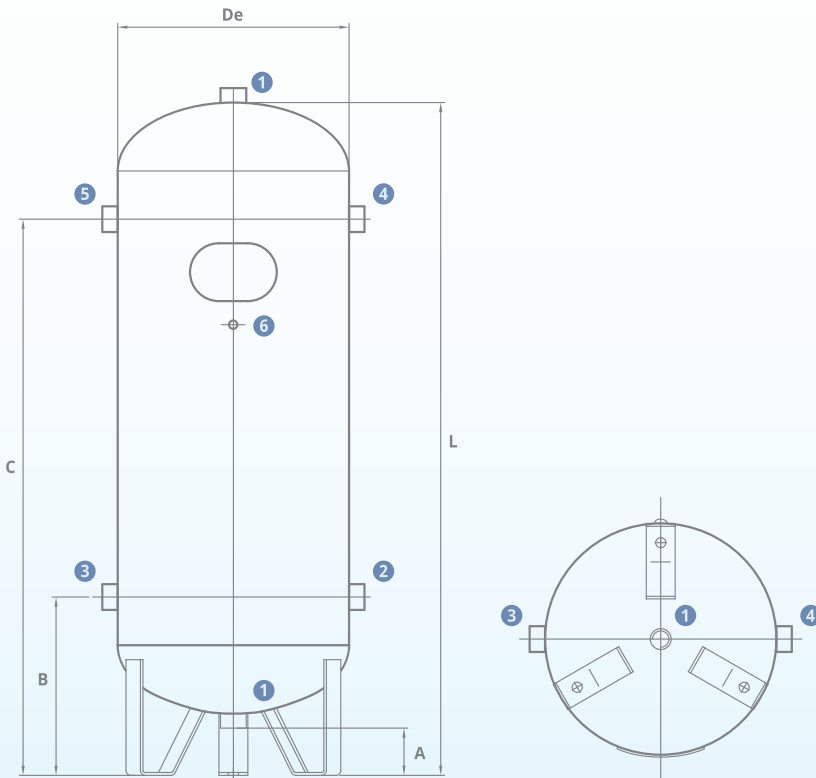

CODE	DIRECTIVE	CAPACITY	OPERATING PRESSURE	De	A	B	C	L	1	2	3	4	5	6	WEIGHT
		Lt	Bar	mm	mm	mm	mm	mm	inch.	inch.	inch.	inch.	inch.	inch.	Kg

## RAL 5015\*

VEC01295	2014/29/UE	24	11	240	64	185	535	656	1/2"	=	1/2"	1/2"	=	3/8"	10
VEC01296	2014/29/UE	50	11	305	145	297	777	929	1/2"	1/2"	=	=	1/2"	3/8"	19
VEC00875	CE 105/2009	50	15	305	145	297	777	929	1/2"	1/2"	=	=	1/2"	3/8"	23

## GALVANIZED

VEC02301	2014/29/UE	24	11	240	64	185	535	656	1"	=	1/2"	1/2"	=	3/8"	11
VEC01736	2014/29/UE	50	11	305	145	297	777	929	1"	1/2"	=	=	1/2"	3/8"	20

-10°C AIR VESSELS

# SMALL SIZE HORIZONTAL PAINTED - GALVANIZED

DIRECTIVE 2014/29/UE  
 OPERATING PRESSURE 11/16 bar  
 OPERATING TEMPERATURE -10 +120°C

**MATERIAL**

Carbon steel

**FLUID CONTENT**

Compressed air / Nitrogen (group 2)

**FINISHING**

**RAL5015:** External Ral 5015 blue paint (standard)

**GALVANIZED:** internal and external hot-dip galvanization

**UPON REQUEST**

1" couplings on heads

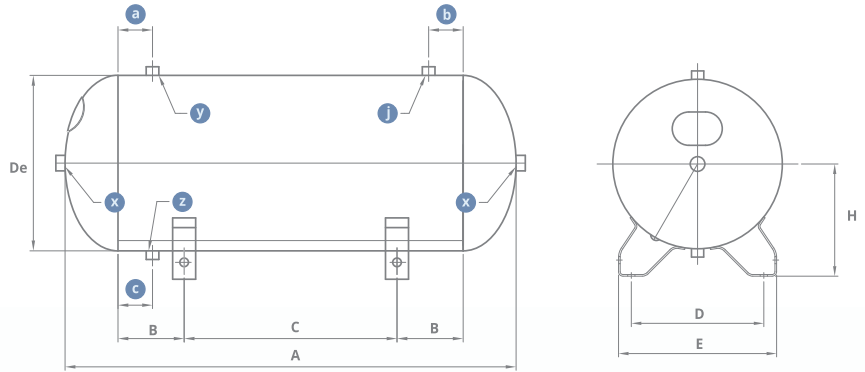

## HORIZONTAL VESSELS WITH FIXED FEET

CODE	DIRECTIVE	CAPACITY	OPERATING PRESSURE	De	A	B	C	D	E	H	a	b	c	x	y	j	z	WEIGHT
		Lt	Bar	mm	mm	mm	mm	mm	mm	mm	mm	mm	mm	inch.	inch.	inch.	inch.	Kg

### RAL 5015\*

VEC01294	2014/29/UE	5	11	150	370	37,5	200	140	191	120	-	-	137,5	1/2"	-	-	1/4"	6,5
VEC01249	2014/29/UE	10	11	169	506	85	240	172	205	115	-	60	50	1/2"	-	3/8"	3/8"	8
VEC01237	2014/29/UE	15	11	196	522	85	240	172	205	135	-	60	50	1/2"	-	3/8"	3/8"	9
VEC01250	2014/29/UE	24	11	240	592	95	260	180	235	165	-	60	50	1/2"	-	3/8"	3/8"	10
VEC01251	2014/29/UE	50	11	305	784	100	400	236	285	203	60	60	60	1/2"	1/2"	1/2"	3/8"	19
VEC01715	2014/29/UE	24	16	240	592	95	260	180	235	165	-	60	50	1/2"	-	3/8"	3/8"	13
VEC02313	2014/29/UE	50	15	305	784	100	400	236	285	203	60	60	60	1/2"	1/2"	1/2"	3/8"	23

### GALVANIZED

VEC03220	2014/29/UE	10	11	169	506	85	240	172	205	115	-	60	50	1"	-	3/8"	3/8"	8
VEC04702	2014/29/UE	15	11	196	522	85	240	172	205	135	-	60	50	1"	-	3/8"	3/8"	9
VEC03019	2014/29/UE	24	11	240	592	95	260	180	235	165	-	60	50	1"	-	3/8"	3/8"	10
VEC02779	2014/29/UE	50	11	305	784	100	400	236	285	203	60	60	60	1"	1/2"	1/2"	3/8"	19

# HORIZONTAL PAINTED

### MATERIAL

Carbon steel

### FLUID CONTENT

Compressed air / Nitrogen (group 2)

### FINISHING

External Ral 5015 blue paint (standard)

### UPON REQUEST

1" couplings on heads

DIRECTIVE

2014/29/UE

2014/68/U E(PED)

OPERATING PRESSURE

11/16 bar

12/16 bar

OPERATING TEMPERATURE

-10 +120°C

-10 +50°C

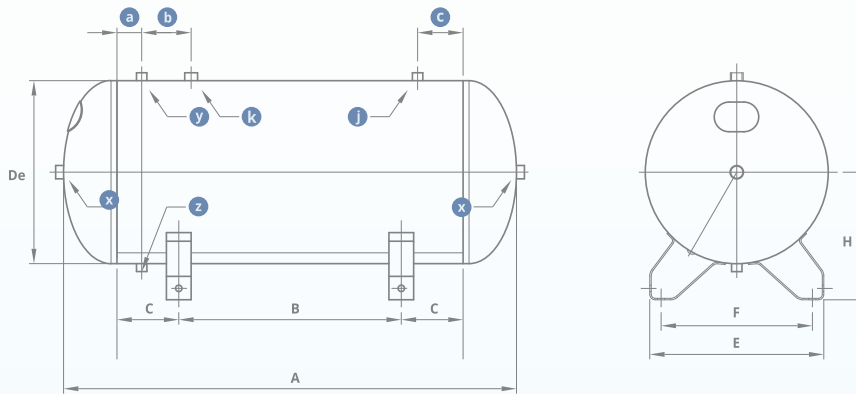
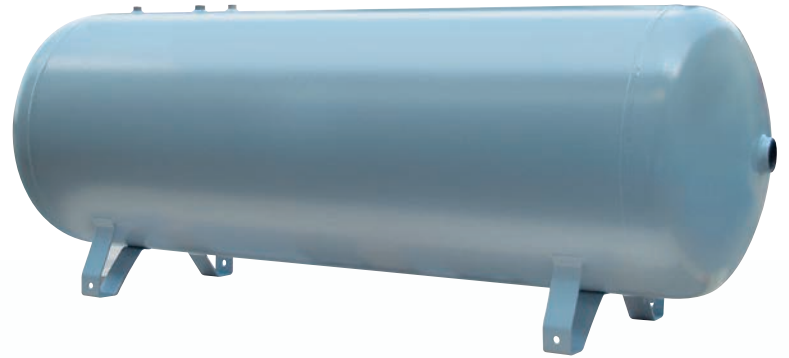

CODE	DIRECTIVE	CAPACITY	OPERATING PRESSURE	De	A	B	C	E	F	H	a	b	c	x	y	k	j	z	WEIGHT
		Lt	Bar	mm	mm	mm	mm	mm	mm	mm	mm	mm	mm	mm	inch.	inch.	inch.	inch.	Kg

## RAL 5015\*

VEC01095	2014/29/UE	100	11	370	1016	550	125	352	306	258	45	80	45	2"	3/8"	1/2"	3/8"	3/8"	29
VEC02139	2014/29/UE	150	11	396	1240	650	175	368	322	271	50	130	50	2"	3/8"	1/2"	3/8"	3/8"	44
VEC01732	2014/29/UE	200	11	446	1364	750	175	440	385	288	50	150	50	2"	3/8"	1/2"	1/2"	3/8"	55
VEC01733	2014/29/UE	270	11	500	1458	800	175	455	402	315	50	130	50	2"	3/8"	1"	1/2"	3/8"	67
VEC00728	2014/29/UE	500	11	600	1858	1204	148	530	470	396	60	155	60	2"	3/8"	1"	1/2"	3/8"	130
VEC0007240	2014/29/UE	720	11	800	1560	700	200	470	500	60	155	60	2"	3/8"	1"	1/2"	3/8"	180	
VEC00707	2014/29/UE	900	11	800	1960	1000	243	605	470	500	60	155	60	2"	3/4"	1"	1/2"	1/2"	194
VEC00515	2014/68/UE(PED)	1000	12	800	2158	1000	343	605	470	500	100	155	60	2"	3/4"	1"	1/2"	1/2"	210
VEC00739	2014/68/UE(PED)	1500	12	1000	2135	900	300	691	575	608	200	200	-	2"	1/2"	1/2"	-	1/2"	325
VEC00680	2014/68/UE(PED)	2000	12	1100	2252	1100	275	800	685	652	200	215	-	2"	1/2"	1/2"	-	1/2"	394
VEC00534	2014/68/UE(PED)	3000	12	1200	2850	1265	227	820	710	698	1230	200	-	2"	1/2"	1/2"	-	1/2"	605
VEC02257	2014/29/UE	270	16	500	1484	800	175	455	402	315	50	130	50	2"	3/8"	1"	1/2"	3/8"	104
VEC01113	2014/29/UE	500	16	600	1858	1204	148	530	470	396	60	155	60	2"	3/8"	1"	1/2"	3/8"	163
VEC00520	2014/68/UE(PED)	1000	16	800	2158	1014	343	605	490	500	100	155	60	2"	3/4"	1"	1/2"	1/2"	253
VEC00531	2014/68/UE(PED)	2000	16	1000	2570	1350	300	691	575	608	220	300	-	2"	1/2"	1/2"	-	1/2"	395
VEC02912	2014/68/UE(PED)	3000	16	1200	2850	1265	227	820	710	698	1230	200	-	2"	1/2"	1/2"	-	1/2"	640



# HORIZONTAL GALVANIZED - ALM

## MATERIAL

Carbon steel

## FLUID CONTENT

Compressed air / Nitrogen (group 2)

## FINISHING

**GALVANIZED:** internal and external hot-dip galvanization

**ALM:** External Ral 5015 blue paint (standard) and Internal Ral 5005 ALM paint

## UPON REQUEST

1" couplings on heads

DIRECTIVE

2014/29/UE

2014/68/UE(PED)

OPERATING PRESSURE

11/16 bar

12/16 bar

OPERATING TEMPERATURE

-10 +120°C

-10 +50°C

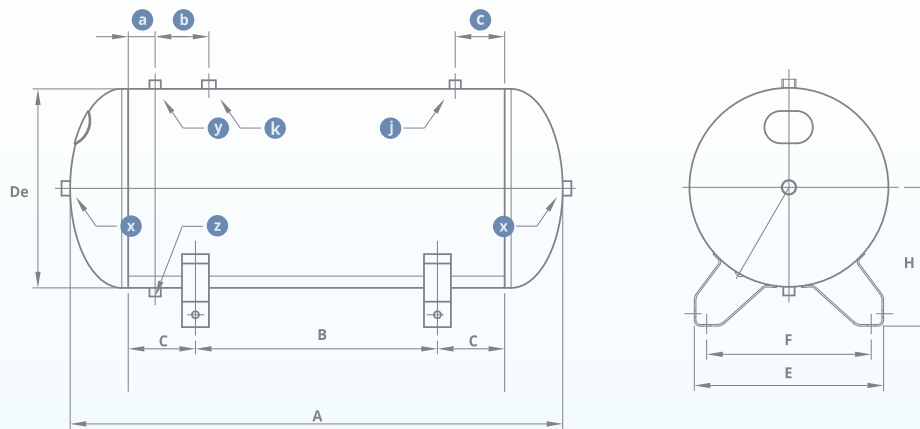

CODE	DIRECTIVE	CAPACITY	OPERATING PRESSURE	De	A	B	C	E	F	H	a	b	c	x	y	k	j	z	WEIGHT
		Lt	Bar	mm	mm	mm	mm	mm	mm	mm	mm	mm	mm	mm	inch.	inch.	inch.	inch.	Kg

## GALVANIZED

VEC01735	2014/29/UE	270	11	500	1458	800	175	455	402	315	50	130	50	2"	3/8"	1"	1/2"	3/8"	70
VEC00874	2014/29/UE	500	11	600	1858	1204	148	530	470	396	60	155	60	2"	3/8"	1"	1/2"	3/8"	134
VEC0007241	2014/29/UE	720	11	800	1560	700	200	580	470	500	60	155	60	2"	3/8"	1"	1/2"	3/8"	185
VEC02277	2014/68/UE(PED)	1000	12	800	2158	1014	343	605	490	500	100	155	60	2"	3/4"	1"	1/2"	1/2"	215
VEC00690	2014/68/UE(PED)	2000	12	1100	2252	1100	275	800	685	652	200	215	-	2"	1/2"	1/2"	-	1/2"	398
VEC02202	2014/68/UE(PED)	3000	12	1200	2850	1265	227	820	710	698	1230	200	-	2"	1/2"	1/2"	-	1/2"	609

## ALM

VEC02317	2014/29/UE	270	11	500	1458	800	175	455	402	315	50	130	50	2"	3/8"	1"	1/2"	3/8"	67
VEC02127	2014/29/UE	500	11	600	1858	1204	148	530	470	396	60	155	60	2"	3/8"	1"	1/2"	3/8"	130
VEC0007355	2014/29/UE	720	11	800	1560	700	200	580	470	500	60	155	60	2"	3/8"	1"	1/2"	3/8"	182
VEC02285	2014/68/UE(PED)	1000	12	800	2158	1014	343	605	490	500	100	155	60	2"	3/4"	1"	1/2"	1/2"	210
VEC02100	2014/68/UE(PED)	2000	12	1100	2252	1100	275	800	685	652	200	215	-	2"	1/2"	1/2"	-	1/2"	394
VEC02284	2014/68/UE(PED)	3000	12	1200	2850	1265	227	820	710	698	1230	200	-	2"	1/2"	1/2"	-	1/2"	605

# HORIZONTAL WITH PLATE PAINTED - GALVANIZED

DIRECTIVE 2014/29/UE  
 OPERATING PRESSURE 11 bar  
 OPERATING TEMPERATURE -10 +120°C

**MATERIAL**

Carbon steel

**FLUID CONTENT**

Compressed air / Nitrogen (group 2)

**FINISHING**

**RAL5015:** External Ral 5015 blue paint (standard)

**GALVANIZED:** internal and external hot-dip galvanization

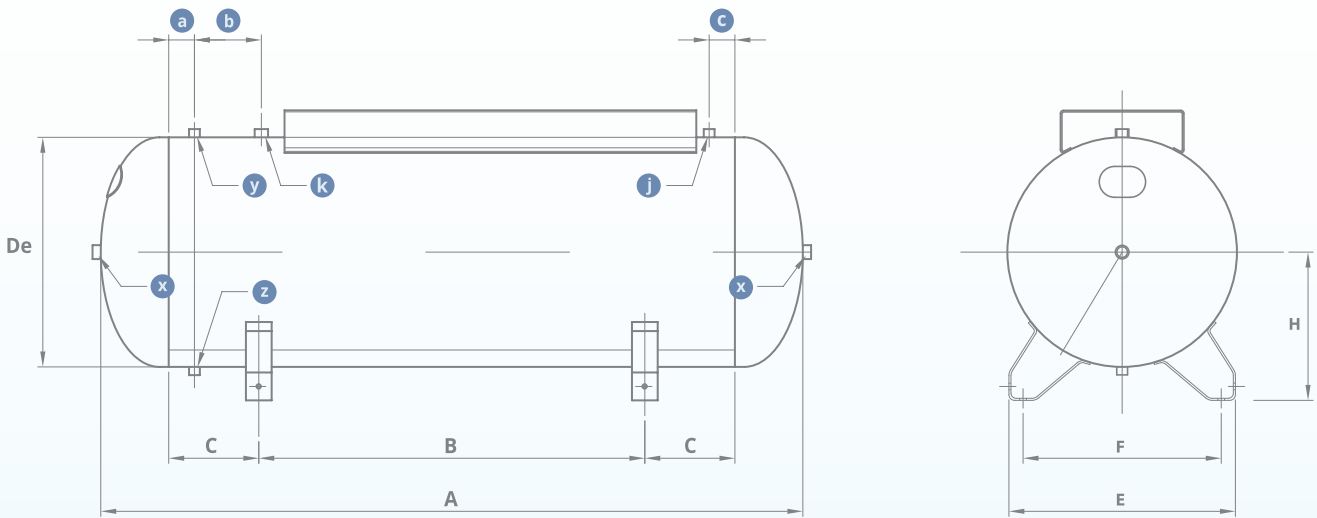

CODE	DIRECTIVE	CAPACITY	OPERATING PRESSURE	De	A	B	C	E	F	H	a	b	c	x	y	k	j	z	PLATE DIMENSIONS	WEIGHT	
		Lt	Bar	mm	mm	mm	mm	mm	mm	mm	mm	mm	mm	inch.	inch.	inch.	inch.	inch.	mm	mm	Kg

## RAL 5015\*

VEC04713	2014/29/UE	50	11	305	784	100	400	239	285	203	60	60	60	1/2"	1/2"	-	1/2"	3/8"	220	400	24
VEC04711	2014/29/UE	100	11	370	1016	550	125	352	306	258	45	80	45	1/2"	3/8"	1/2"	3/8"	3/8"	220	400	34
VEC04709	2014/29/UE	200	11	446	1364	750	175	440	385	288	50	130	50	1/2"	3/8"	1/2"	1/2"	3/8"	240	800	65
VEC04707	2014/29/UE	270	11	500	1458	800	175	456	402	315	50	130	50	1/2"	3/8"	1"	1/2"	3/8"	240	800	77
VEC04705	2014/29/UE	500	11	600	1858	1205	148	530	470	396	60	155	60	2"	3/8"	1"	1/2"	3/8"	300	800	143

## GALVANIZED

VEC04714	2014/29/UE	50	11	305	784	100	400	239	285	203	60	60	60	1"	1/2"	-	1/2"	3/8"	220	400	25
VEC04712	2014/29/UE	100	11	370	1016	550	125	352	306	258	45	80	45	2"	3/8"	1/2"	3/8"	3/8"	220	400	38
VEC04710	2014/29/UE	200	11	446	1364	750	175	440	385	288	50	130	50	2"	3/8"	1/2"	1/2"	3/8"	240	800	70
VEC04708	2014/29/UE	270	11	500	1458	800	175	456	402	315	50	130	50	2"	3/8"	1"	1/2"	3/8"	240	800	81
VEC04706	2014/29/UE	500	11	600	1858	1205	148	530	470	396	60	155	60	2"	3/8"	1"	1/2"	3/8"	300	800	149

# VERTICAL

PAINTED

11 • 12 • 16 bar

**MATERIAL**

Carbon steel

**FLUID CONTENT**

Compressed air / Nitrogen (group 2)

**FINISHING**

External Ral 5015 blue paint (standard)

DIRECTIVE

2014/29/UE

2014/68/UE(PED)

OPERATING PRESSURE

11/16 bar

12/16 bar

OPERATING TEMPERATURE

-10 +120°C

-10 +50°C

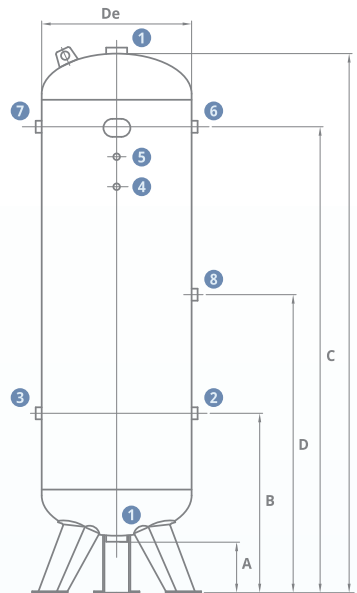
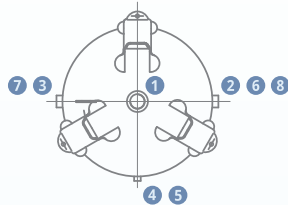

CODE	DIRECTIVE	CAPACITY	OPERATING PRESSURE	De	A	B	C	D	L	1	2	3	4	5	6	7	8	WEIGHT
		Lt	Bar	mm	mm	mm	mm	mm	mm	inch.	inch.	inch.	inch.	inch.	inch.	inch.	inch.	Kg

**RAL 5015\***

VEC00644	2014/29/UE	100	11	370	180	355	1055	=	1213	1/2"	3/4"	=	3/8"	3/8"	=	3/4"	=	31
VEC00709	2014/29/UE	150	11	396	170	385	1210	=	1430	1/2"	1"	=	3/8"	3/8"	=	1"	=	44
VEC00645	2014/29/UE	200	11	446	175	400	1225	=	1557	1/2"	1"	=	3/8"	3/8"	=	1"	=	55
VEC00478	2014/29/UE	270	11	500	175	599	1304	=	1648	1/2"	1"	1"	=	3/8"	1"	=	=	67
VEC00493	2014/29/UE	500	11	600	155	785	1665	=	2050	1/2"	1"	1"	=	3/8"	1"	1"	=	115
VEC00370	2014/29/UE	500	11	600	155	785	1665	=	2050	2"	2"	2"	=	3/8"	2"	2"	=	116
VEC06236	2014/29/UE	720	11	800	145	580	1310	=	1745	2"	2"	2"	3/8"	3/8"	2"	2"	=	155
VEC05025	2014/29/UE	900	11	800	145	875	1805	=	2140	2"	2"	2"	3/8"	3/8"	2"	2"	=	194
VEC00518	2014/68/UE(PED)	1000	12	800	145	770	1720	=	2350	2"	2"	2"	3/8"	3/8"	2"	2"	=	210
VEC00525	2014/68/UE(PED)	1500	12	1000	170	680	1780	=	2305	2"	2"	2"	1/2"	1/2"	2"	2"	=	320
VEC00528	2014/68/UE(PED)	2000	12	1100	200	770	1970	=	2490	2"	2"	2"	1/2"	1/2"	2"	2"	=	388
VEC00530	2014/68/UE(PED)	2000	12	1100	200	770	1970	=	2490	2"	3"	3"	1/2"	1/2"	3"	3"	=	390
VEC00535	2014/68/UE(PED)	3000	12	1200	140	830	2250	1540	2990	2"	2"	2"	1/2"	1/2"	2"	2"	2"	594
VEC01360	2014/68/UE(PED)	3000	12	1200	140	830	2250	1540	2990	2"	3"	3"	1/2"	1/2"	3"	3"	3"	596
VEC00879	2014/29/UE	270	16	500	175	599	1304	=	1648	1/2"	1"	1"	=	3/8"	1"	=	=	101
VEC00139	2014/29/UE	500	16	600	155	785	1665	=	2050	2"	2"	2"	=	3/8"	2"	2"	=	145
VEC00366	2014/68/UE(PED)	1000	16	800	145	770	1720	=	2350	2"	2"	2"	3/8"	3/8"	2"	2"	=	245
VEC01058	2014/68/UE(PED)	1500	16	1000	170	680	1780	=	2305	2"	2"	2"	1/2"	1/2"	2"	2"	=	423
VEC00532	2014/68/UE(PED)	2000	16	1000	170	770	2185	=	2740	2"	2"	2"	1/2"	1/2"	2"	2"	=	450
VEC00537	2014/68/UE(PED)	3000	16	1200	140	830	2250	1540	2990	2"	2"	2"	1/2"	1/2"	2"	2"	2"	630

# VERTICAL

## GALVANIZED

11 • 12 • 16 bar

### MATERIAL

Carbon steel suitable for galvanization

### FLUID CONTENT

Compressed air / Nitrogen (group 2)

### FINISHING

Internal and external hot-dip galvanization

### DIRECTIVE

2014/29/UE

2014/68/UE(PED)

### OPERATING PRESSURE

11/16 bar

12/16 bar

### OPERATING TEMPERATURE

-10 +120°C

-10 +50°C

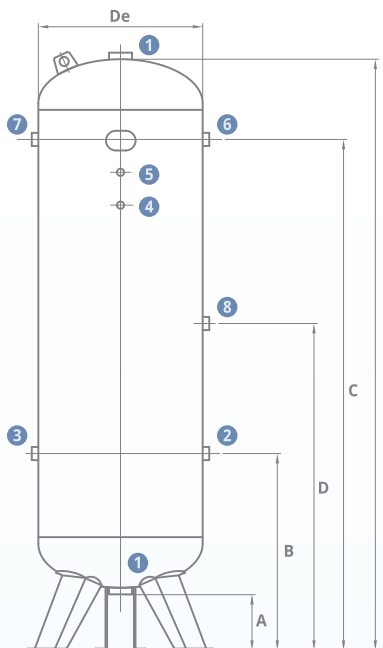
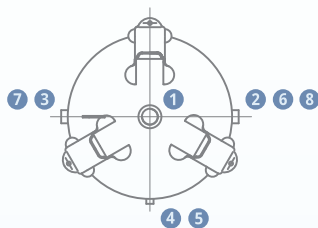

CODE	DIRECTIVE	CAPACITY	OPERATING PRESSURE	De	A	B	C	D	L	1	2	3	4	5	6	7	8	WEIGHT
		Lt	Bar	mm	mm	mm	mm	mm	mm	inch.	inch.	inch.	inch.	inch.	inch.	inch.	inch.	Kg

## GALVANIZED

VEC00901	2014/29/UE	100	11	370	170	355	1055	=	1213	2"	3/4"	=	3/8"	3/8"	=	3/4"	=	32
VEC02471	2014/29/UE	150	11	396	170	385	1210	=	1430	2"	1"	=	3/8"	3/8"	=	1"	=	46
VEC00908	2014/29/UE	200	11	446	170	400	1225	=	1557	2"	1"	=	3/8"	3/8"	=	1"	=	57
VEC00909	2014/29/UE	270	11	500	170	599	1304	=	1648	2"	1"	1"	=	3/8"	1"	=	=	70
VEC00906	2014/29/UE	500	11	600	155	785	1665	=	2050	2"	2"	2"	=	3/8"	2"	2"	=	119
VEC05980	2014/29/UE	720	11	800	145	580	1310	=	1745	2"	2"	2"	3/8"	3/8"	2"	2"	=	155
VEC04703	2014/29/UE	900	11	800	145	875	1805	=	2140	2"	2"	2"	3/8"	3/8"	2"	2"	=	198
VEC00519	2014/68/UE(PED)	1000	12	800	145	770	1720	=	2350	2"	2"	2"	2"	3/8"	3/8"	2"	=	214
VEC00526	2014/68/UE(PED)	1500	12	1000	170	680	1780	=	2305	2"	2"	2"	2"	1/2"	1/2"	2"	=	325
VEC00529	2014/68/UE(PED)	2000	12	1100	200	770	1970	=	2490	2"	2"	2"	2"	1/2"	1/2"	2"	=	394
VEC02276	2014/68/UE(PED)	2000	12	1100	200	770	1970	=	2490	2"	3"	3"	1/2"	1/2"	3"	3"	=	398
VEC00536	2014/68/UE(PED)	3000	12	1200	140	830	2250	1540	2990	2"	2"	2"	2"	1/2"	1/2"	2"	2"	600
VEC01368	2014/68/UE(PED)	3000	12	1200	140	830	2250	1540	2990	2"	3"	3"	1/2"	1/2"	3"	3"	3"	604
VEC00900	2014/29/UE	270	16	500	170	599	1304	=	1648	2"	1"	1"	=	3/8"	1"	=	=	104
VEC00500	2014/29/UE	500	16	600	155	785	1665	=	2050	2"	2"	2"	=	3/8"	2"	2"	=	149
VEC00402	2014/68/UE(PED)	1000	16	800	150	770	1720	=	2350	2"	2"	2"	3/8"	3/8"	2"	2"	=	249
VEC02278	2014/68/UE(PED)	1500	16	1000	170	680	1780	=	2305	2"	2"	2"	1/2"	1/2"	2"	2"	=	428
VEC00533	2014/68/UE(PED)	2000	16	1000	170	770	2185	=	2740	2"	2"	2"	1/2"	1/2"	2"	2"	=	455
VEC00538	2014/68/UE(PED)	3000	16	1200	140	830	2250	1540	2990	2"	2"	2"	1/2"	1/2"	2"	2"	2"	635

# VERTICAL

ALM 11 • 12 • 16 bar

### MATERIAL

Carbon steel suitable for galvanization

### FLUID CONTENT

Compressed air / Nitrogen (group 2)

### FINISHING

External Ral 5015 blue paint (standard)

Internal Ral 5005 ALM paint

DIRECTIVE

2014/29/UE

2014/68/UE(PED)

OPERATING PRESSURE

11/16 bar

12/16 bar

OPERATING TEMPERATURE

-10 +120°C

-10 +50°C

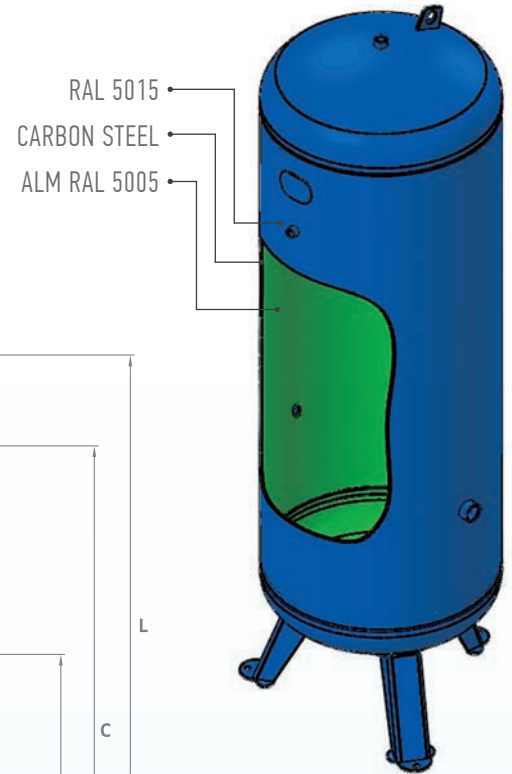
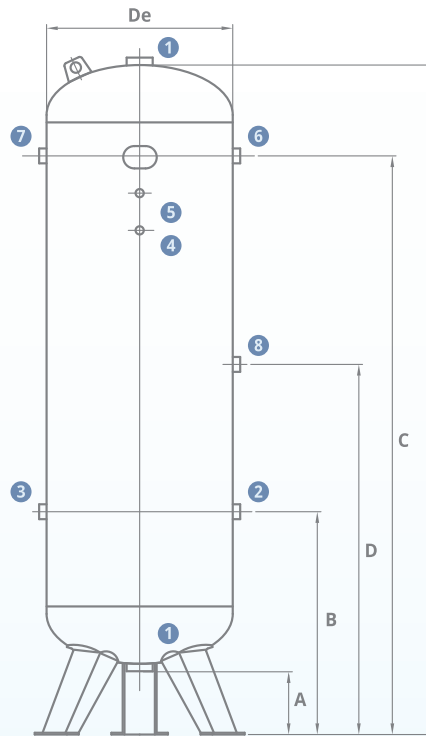
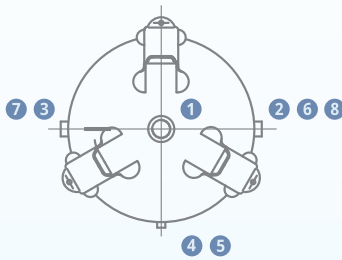

CODE	DIRECTIVE	CAPACITY	OPERATING PRESSURE	De	A	B	C	D	L	1	2	3	4	5	6	7	8	WEIGHT
		Lt	Bar	mm	mm	mm	mm	mm	mm	mm	mm	mm	mm	inch.	inch.	inch.	inch.	Kg

## ALM

VEC01125	2014/29/UE	270	11	500	170	599	1304	=	1648	2"	1"	1"	=	3/8"	1"	=	=	67
VEC01118	2014/29/UE	500	11	600	155	785	1665	=	2050	2"	2"	2"	=	3/8"	2"	2"	=	116
VEC01119	2014/29/UE	720	11	800	145	880	1310	=	1745	2"	2"	2"	3/8"	3/8"	2"	2"	=	155
VEC01120	2014/29/UE	900	11	800	145	875	1805	=	2140	2"	2"	2"	3/8"	3/8"	2"	2"	=	194
VEC01116	2014/68/UE(PED)	1000	12	800	145	770	1720	=	2350	2"	2"	2"	3/8"	3/8"	2"	2"	=	210
VEC01121	2014/68/UE(PED)	1500	12	1000	170	680	1780	=	2305	2"	2"	2"	1/2"	1/2"	2"	2"	=	320
VEC01122	2014/68/UE(PED)	2000	12	1100	200	770	1970	=	2490	2"	2"	2"	1/2"	1/2"	2"	2"	=	388
VEC01123	2014/68/UE(PED)	3000	12	1200	140	830	2250	1540	2990	2"	2"	2"	1/2"	1/2"	2"	2"	2"	594
VEC01935	2014/29/UE	270	16	500	175	599	1304	=	1648	1/2"	1"	1"	=	3/8"	1"	=	=	101
VEC02279	2014/29/UE	500	16	600	155	785	1665	=	2050	2"	2"	2"	=	3/8"	2"	2"	=	145
VEC02310	2014/68/UE(PED)	1000	16	800	145	770	1720	=	2350	2"	2"	2"	3/8"	3/8"	2"	2"	=	245
VEC02143	2014/68/UE(PED)	2000	16	1000	170	770	2185	=	2740	2"	2"	2"	1/2"	1/2"	2"	2"	=	450
VEC02464	2014/68/UE(PED)	3000	16	1200	140	830	2250	1540	2990	2"	2"	2"	1/2"	1/2"	2"	2"	2"	630

# VERTICAL VACUUM PAINTED

### MATERIAL

Carbon steel

### FLUID CONTENT

Compressed air / Nitrogen (group 2)

### FINISHING

External Ral 5015 blue paint (standard)

### UPON REQUEST

Horizontal version

DIRECTIVE

Manufacturer testing

OPERATING PRESSURE

-1 bar

OPERATING TEMPERATURE

-10 +120°C

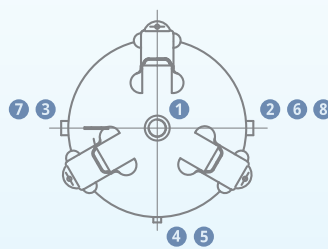
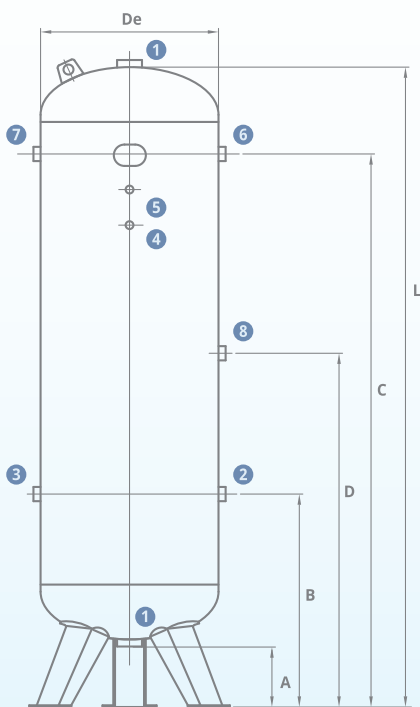
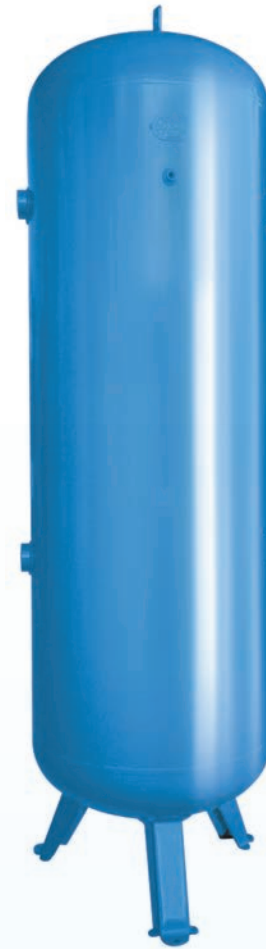

A vacuum system is required in certain industrial process operations in order to prevent chemical or physical processes caused by the action of atmospheric gases.

The vessels are used to reproduce a setting where gas pressure is lower than the atmospheric one. Vacuum vessels are not governed by any Directive and are therefore excluded from CE marking requirements.

All vessels are supplied with name plate bearing Manufacturer's name, operating temperature, operating pressure and product's serial number.

CODE	DIRECTIVE	CAPACITY	OPERATING PRESSURE	De	A	B	C	D	L	1	2	3	4	5	6	7 - 8	WEIGHT
		Lt	Bar	mm	mm	mm	mm	mm	mm	inch.	inch.	inch.	inch.	inch.	inch.	inch.	Kg

## RAL 5015\*

VAC00041	=====	100	-1	370	180	355	1055	=	1213	2"	3/4"	=	3/8"	3/8"	=	3/4	40
VAC00012	=====	270	-1	500	170	599	1304	=	1648	2"	1"	1"	=	3/8"	1"	=	101
VAC00005	=====	500	-1	600	155	785	1665	=	2050	2"	2"	2"	=	3/8"	2"	2"	145
VAC00004	=====	1000	-1	800	145	760	1700	=	2350	2"	2"	2"	3/8"	3/8"	2"	2"	245
VAC00006	=====	2000	-1	1100	200	770	1970	=	2490	2"	2"	2"	1/2"	1/2"	2"	2"	450
VAC00013	=====	3000	-1	1200	140	830	2250	1540	2990	2"	2"	2"	1/2"	1/2"	2"	2"	630

# VERTICAL AUTOCLAVE GALVANIZED

DIRECTIVE 2014/68/UE(PED)  
 OPERATING PRESSURE 8 bar  
 OPERATING TEMPERATURE -10 +50°C

**MATERIAL**

Carbon steel suitable for galvanization

**FLUID CONTENT**

Compressed air / Water (group 2)

**FINISHING**

Internal and external hot-dip galvanization

**UPON REQUEST**

Horizontal version

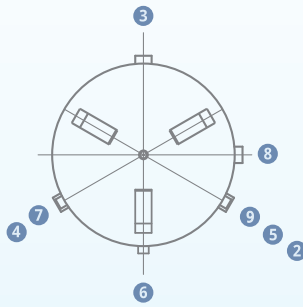
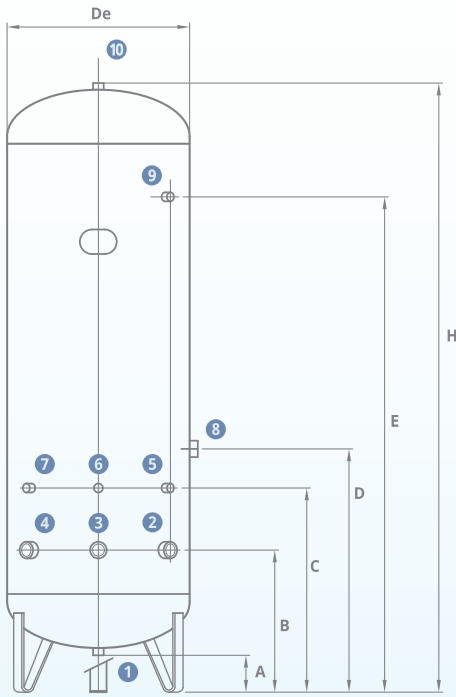

CODE	DIRECTIVE	CAPACITY	OPERATING PRESSURE	DE	A	B	C	D	E	L	1	2-3-4	5-6-7	8	9	10	WEIGHT
		Lt	Bar	mm	mm	mm	mm	mm	mm	mm	inch.	inch.	inch.	inch.	inch.	inch.	Kg

## GALVANIZED

VEC01254	2014/68/UE(PED)	100	8	370	85	345	515	615	815	1145	2"	1"	1/2"	1"1/4	1/2"	2"	34
VEC01256	2014/68/UE(PED)	200	8	446	80	360	684	784	1184	1488	2"	1"	1/2"	1"1/4	1/2"	2"	57
VEC01257	2014/68/UE(PED)	200	8	500	80	360	669	769	1160	1461	2"	1"	1/2"	1"1/4	1/2"	2"	59
VEC01259	2014/68/UE(PED)	300	8	500	130	425	856	956	1356	1782	2"	1"1/4	1/2"	1"1/4	1/2"	2"	73
VEC01260	2014/68/UE(PED)	300	8	550	130	432	732	832	1225	1530	2"	1"1/4	1/2"	1"1/4	1/2"	2"	73
VEC01261	2014/68/UE(PED)	500	8	600	120	440	944	1044	1594	1968	2"	1"1/2	1/2"	1"1/4	1/2"	2"	106
VEC01262	2014/68/UE(PED)	500	8	650	120	440	840	940	1490	1802	2"	1"1/2	1/2"	1"1/4	1/2"	2"	94
VEC01264	2014/68/UE(PED)	750	8	750	100	500	950	1050	1700	1984	2"	2"	1/2"	1"1/4	1/2"	2"	125
VEC01265	2014/68/UE(PED)	750	8	800	110	465	865	965	1430	1820	2"	2"	1/2"	1"1/4	1/2"	2"	127
VEC01266	2014/68/UE(PED)	1000	8	800	115	525	1025	1125	1875	2319	2"	2"	1/2"	1"1/4	1/2"	2"	189



**-20°C AIR VESSELS**



# VERTICAL

PAINTED

11 • 12 • 16 bar

### MATERIAL

Carbon steel

### FLUID CONTENT

Compressed air / Nitrogen / Argon / Helium / Oil / Oxygen (group 1 hydrogen excluded)

### FINISHING

External Ral 5015 blue paint (standard)

### UPON REQUEST

Inspection ports

100x150 mm handhole (from 1000 to 3000 lt)

Flanged connections

Horizontal version

DIRECTIVE

2014/68/UE(PED) 2014/68/UE(PED)

OPERATING PRESSURE

11/16 bar 12/16 bar

OPERATING TEMPERATURE

\*-20 +50°C -20 +80°C

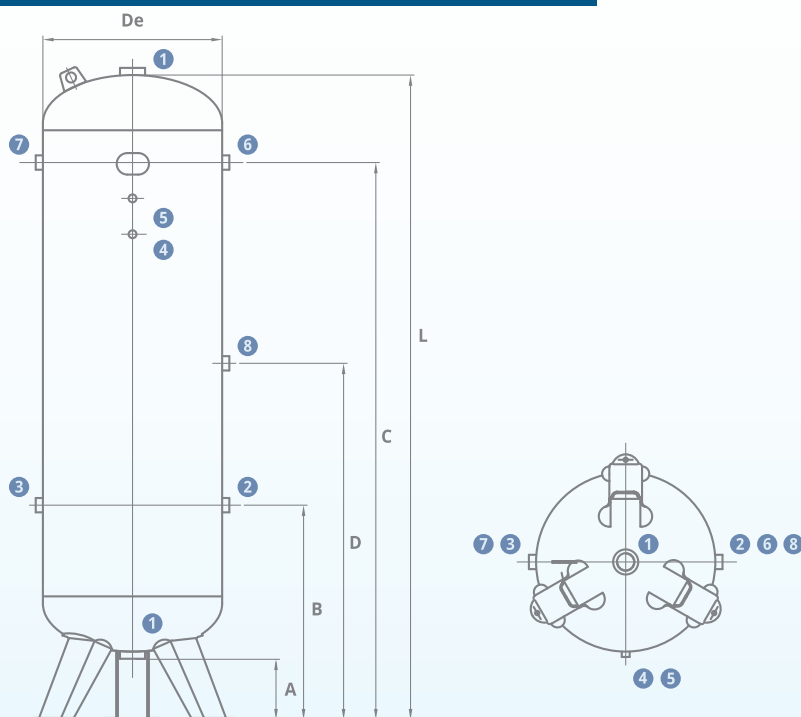

CODE	DIRECTIVE	CAPACITY	OPERATING PRESSURE	De	A	B	C	L	1	2	3	4	5	6	7	WEIGHT
		Lt	Bar	mm	mm	mm	mm	mm	inch.	inch.	inch.	inch.	inch.	inch.	inch.	Kg

## RAL 5015\*

VECO2287	2014/68/UE(PED)	*500	11	600	155	785	1665	2050	2"	2"	2"	=	3/8"	2"	2"	116
VECO1656	2014/68/UE(PED)	1000	12	800	145	770	1720	2350	2"	2"	2"	3/8"	3/8"	2"	2"	210
VECO1987	2014/68/UE(PED)	1500	12	1000	170	680	1780	2305	2"	2"	2"	1/2"	1/2"	2"	2"	320
VECO1657	2014/68/UE(PED)	2000	12	1100	200	770	1970	2490	2"	2"	2"	1/2"	1/2"	2"	2"	388
VECO1658	2014/68/UE(PED)	3000	12	1200	140	830	2250	2990	2"	2"	2"	1/2"	1/2"	2"	2"	594
VECO2289	2014/68/UE(PED)	*500	16	600	155	785	1665	2050	2"	2"	2"	=	3/8"	2"	2"	145
VECO1918	2014/68/UE(PED)	1000	16	800	145	770	1720	2350	2"	2"	2"	3/8"	3/8"	2"	2"	245
VECO2290	2014/68/UE(PED)	1500	16	1000	170	680	1780	2305	2"	2"	2"	1/2"	1/2"	2"	2"	423
VECO2288	2014/68/UE(PED)	2000	16	1000	170	800	2130	2740	2"	2"	2"	1/2"	1/2"	2"	2"	450
VECO2051	2014/68/UE(PED)	3000	16	1200	140	830	2250	2990	2"	2"	2"	1/2"	1/2"	2"	2"	630

# VERTICAL GALVANIZED - ALM

11 • 12 • 16 bar

### MATERIAL

Carbon steel

### FLUID CONTENT

Compressed air / Nitrogen / Argon / Helium /  
Oil / Oxygen (group 1 hydrogen excluded)

### FINISHING

**GALVANIZED:** internal and external hot-dip galvanization

**ALM:** External Ral 5015 blue paint (standard) and Internal Ral 5005 ALM paint

### UPON REQUEST

Inspection ports

100x150 mm handhole (from 1000 to 3000 lt)

Flanged connections

Horizontal version

DIRECTIVE

2014/68/UE(PED) 2014/68/UE(PED)

OPERATING PRESSURE

11 bar 12 bar

OPERATING TEMPERATURE

\*-20 +50°C -20 +80°C

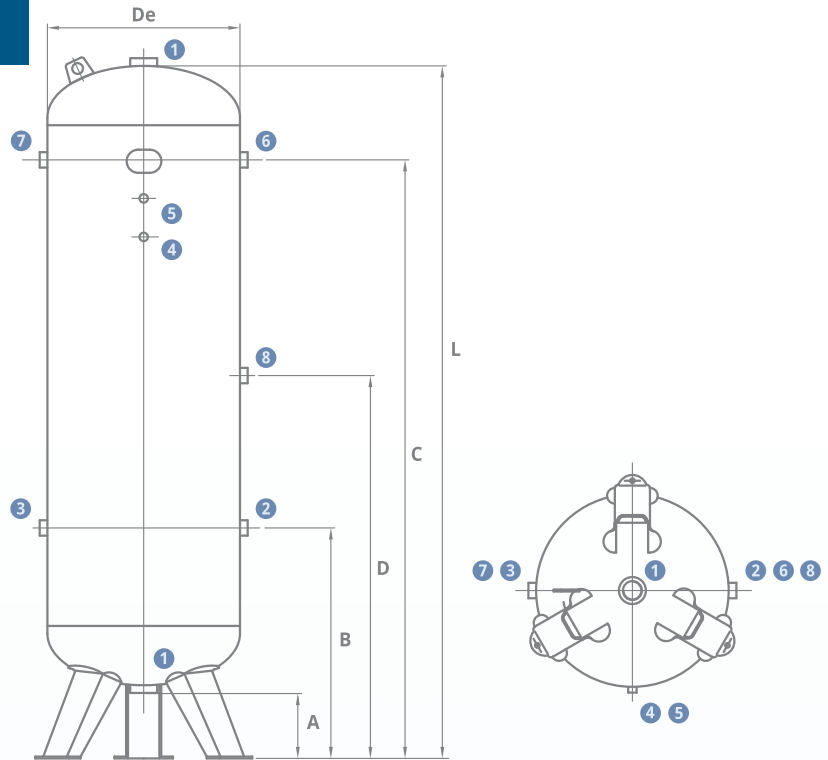

CODE	DIRECTIVE	CAPACITY	OPERATING PRESSURE	De	A	B	C	L	1	2	3	4	5	6	7	WEIGHT
		Lt	Bar	mm	mm	mm	mm	mm	inch.	inch.	inch.	inch.	inch.	inch.	inch.	Kg

## GALVANIZED

VEC02291	2014/68/UE(PED)	*500	11	600	155	785	1665	2050	2"	2"	2"	=	3/8"	2"	2"	119
VEC02292	2014/68/UE(PED)	1000	12	800	145	770	1720	2350	2"	2"	2"	3/8"	3/8"	2"	2"	214
VEC02293	2014/68/UE(PED)	1500	12	1000	170	680	1780	2305	2"	2"	2"	1/2"	1/2"	2"	2"	325
VEC02294	2014/68/UE(PED)	2000	12	1100	200	770	1970	2490	2"	2"	2"	1/2"	1/2"	2"	2"	394
VEC02295	2014/68/UE(PED)	3000	12	1200	140	830	2250	2990	2"	2"	2"	1/2"	1/2"	2"	2"	600
VEC02296	2014/68/UE(PED)	*500	16	600	155	785	1665	2050	2"	2"	2"	=	3/8"	2"	2"	149
VEC02297	2014/68/UE(PED)	1000	16	800	145	770	1720	2350	2"	2"	2"	3/8"	3/8"	2"	2"	249
VEC02298	2014/68/UE(PED)	1500	16	1000	170	680	1780	2305	2"	2"	2"	1/2"	1/2"	2"	2"	428
VEC02299	2014/68/UE(PED)	2000	16	1000	170	800	2130	2740	2"	2"	2"	1/2"	1/2"	2"	2"	455
VEC02300	2014/68/UE(PED)	3000	16	1200	140	830	2250	2990	2"	2"	2"	1/2"	1/2"	2"	2"	635

## ALM

VEC02302	2014/68/UE(PED)	*500	11	600	155	785	1665	2050	2"	2"	2"	=	3/8"	2"	2"	116
VEC02303	2014/68/UE(PED)	1000	12	800	145	770	1720	2350	2"	2"	2"	3/8"	3/8"	2"	2"	210
VEC02304	2014/68/UE(PED)	1500	12	1000	170	680	1780	2305	2"	2"	2"	1/2"	1/2"	2"	2"	320
VEC02305	2014/68/UE(PED)	2000	12	1100	200	770	1970	2490	2"	2"	2"	1/2"	1/2"	2"	2"	388
VEC02306	2014/68/UE(PED)	3000	12	1200	140	830	2250	2990	2"	2"	2"	1/2"	1/2"	2"	2"	594
VEC02307	2014/68/UE(PED)	*500	16	600	155	785	1665	2050	2"	2"	2"	=	3/8"	2"	2"	145
VEC02074	2014/68/UE(PED)	1000	16	800	145	770	1720	2350	2"	2"	2"	3/8"	3/8"	2"	2"	245
VEC02308	2014/68/UE(PED)	1500	16	1000	170	680	1780	2305	2"	2"	2"	1/2"	1/2"	2"	2"	423
VEC02309	2014/68/UE(PED)	2000	16	1000	170	800	2130	2740	2"	2"	2"	1/2"	1/2"	2"	2"	452
VEC02247	2014/68/UE(PED)	3000	16	1200	140	830	2250	2990	2"	2"	2"	1/2"	1/2"	2"	2"	630

# VERTICAL FOR OXYGEN PAINTED

### MATERIAL

Carbon steel

### FLUID CONTENT

Oxygen (group 1 hydrogen excluded)

### FINISHING

External Ral 9010 white paint

Internal Ral 5005 ALM paint

### UPON REQUEST

Inspection ports

100x150 mm handhole

300x400 mm manhole

Flanged connections

Horizontal version

DIRECTIVE

2014/68/UE(PED)

2014/68/UE(PED)

OPERATING PRESSURE

11 bar

12 bar

OPERATING TEMPERATURE

\*-20 +50°C

-20 +80°C

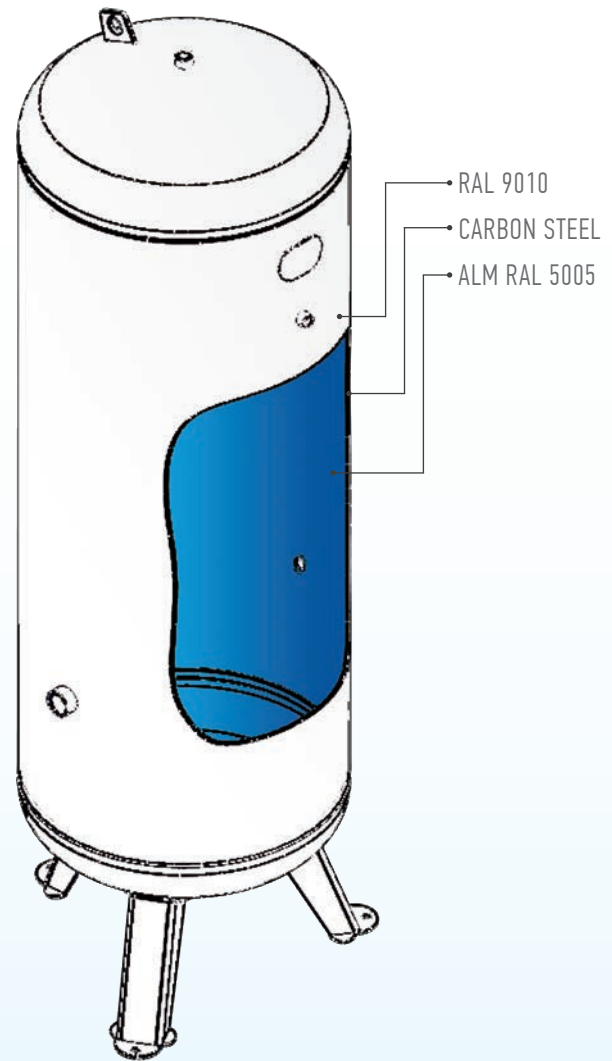

CODE	DIRECTIVE	CAPACITY	OPERATING PRESSURE	De	A	B	C	L	1	2	3	4	5	6	7	WEIGHT
		Lt	Bar	mm	mm	mm	mm	mm	inch.	inch.	inch.	inch.	inch.	inch.	inch.	Kg

## RAL 9010 + ALM

VEC02176	2014/68/UE(PED)	* 500	11	600	155	785	1665	2050	2"	2"	2"	=	3/8"	2"	2"	116
VEC03412	2014/68/UE(PED)	800	12	800	145	875	1605	1940	2"	2"	2"	3/8"	3/8"	2"	2"	180
VEC01719	2014/68/UE(PED)	1000	12	800	145	770	1720	2350	2"	2"	2"	3/8"	3/8"	2"	2"	210
VEC01720	2014/68/UE(PED)	1500	12	1000	170	680	1780	2305	2"	2"	2"	1/2"	1/2"	2"	2"	320
VEC01721	2014/68/UE(PED)	2000	12	1100	200	770	1970	2490	2"	2"	2"	1/2"	1/2"	2"	2"	388
VEC01722	2014/68/UE(PED)	3000	12	1200	140	830	2250	2990	2"	2"	2"	1/2"	1/2"	2"	2"	594
VEC01723	2014/68/UE(PED)	4000	12	1450	225	800	2145	2790	2"	3"	3"	3/4"	3/8"	=	3"	835
VEC01724	2014/68/UE(PED)	5000	12	1450	225	800	2745	3390	2"	3"	3"	3/4"	3/8"	=	3"	962

# VERTICAL OVERSIZE PAINTED

## MATERIAL

Carbon steel

## FLUID CONTENT

Compressed air / Nitrogen / Argon / Helium / Oil / Oxygen (group 1 hydrogen excluded)

## FINISHING

External Ral 5015 blue paint (standard)

## UPON REQUEST

Inspection ports

100x150 mm handhole

300x400 mm manhole

Flanged connections

DIRECTIVE

2014/68/UE(PED)

OPERATING PRESSURE

8/12/16 bar

OPERATING TEMPERATURE

-20 +80°C

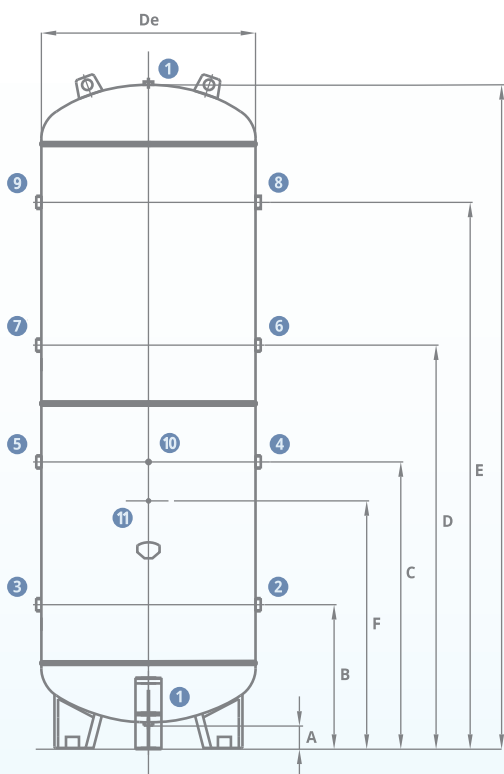
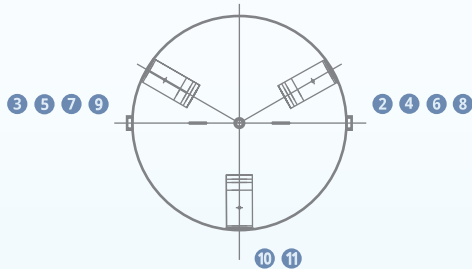

CODE	DIRECTIVE	CAPACITY	OPERATING PRESSURE	DE	A	B	C	D	E	F	L	1	2-3-4-5	6-7-8-9	10	11	WEIGHT
		Lt	Bar	mm	mm	mm	mm	mm	mm	mm	mm	inch.	inch.	inch.	inch.	inch.	Kg

## RAL 5015\*

VEC02311	2014/68/UE(PED)	5000	8	1650	175	1150	2200	=	=	1950	3118	2"	3"	=	3/4"	3/8"	1120
VEC02280	2014/68/UE(PED)	8000	8	1650	175	1150	1930	2460	3310	1680	4318	2"	3"	3"	3/4"	3/8"	1400
VEC02312	2014/68/UE(PED)	10000	8	1650	175	1150	2200	3150	4250	1950	5118	2"	3"	3"	3/4"	3/8"	1730
VEC01297	2014/68/UE(PED)	4000	12	1450	225	800	2145	=	=	=	2790	2"	3"	=	3/4"	3/8"	835
VEC01298	2014/68/UE(PED)	5000	12	1450	225	800	2745	=	=	=	3390	2"	3"	=	3/4"	3/8"	962
VEC00755	2014/68/UE(PED)	5000	12	1650	175	1150	2200	=	=	1950	3118	2"	3"	=	3/4"	3/8"	1360
VEC01299	2014/68/UE(PED)	6000	12	1450	225	800	3345	=	=	=	3990	2"	3"	=	3/4"	3/8"	1090
VEC01300	2014/68/UE(PED)	8000	12	1650	175	1150	1930	2460	3310	1680	4318	2"	3"	3"	3/4"	3/8"	1730
VEC00815	2014/68/UE(PED)	10000	12	1650	175	1150	2200	3150	4250	1950	5118	2"	3"	3"	3/4"	3/8"	2015
VEC02666	2014/68/UE(PED)	4000	16	1450	225	800	2145	=	=	=	2790	2"	3"	=	3/4"	3/8"	995
VEC02667	2014/68/UE(PED)	5000	16	1450	225	800	2745	=	=	=	3390	2"	3"	=	3/4"	3/8"	1145
VEC02668	2014/68/UE(PED)	6000	16	1450	225	800	3345	=	=	=	3990	2"	3"	=	3/4"	3/8"	1295
VEC01899	2014/68/UE(PED)	10000	16	1650	175	1150	2200	3150	4250	1950	5118	2"	3"	3"	3/4"	3/8"	2585

# VERTICAL OVERSIZE GALVANIZED -ALM

DIRECTIVE 2014/68/UE(PED)  
 OPERATING PRESSURE 8/12/16 bar  
 OPERATING TEMPERATURE -20 +80°C

**MATERIAL**

Carbon steel

**FLUID CONTENT**

Compressed air / Nitrogen / Argon / Helium /  
 Oil / Oxygen (group 1 hydrogen excluded)

**FINISHING**

Internal and external hot-dip galvanization  
 Internal Ral 5005 ALM paint

**UPON REQUEST**

Inspection ports  
 100x150 mm handhole  
 300x400 mm manhole  
 Flanged connections



CODE	DIRECTIVE	CAPACITY	OPERATING PRESSURE	DE	A	B	C	D	E	F	L	1	2-3-4-5	6-7-8-9	10	11	WEIGHT
		Lt	Bar	mm	mm	mm	mm	mm	mm	mm	mm	inch.	inch.	inch.	inch.	inch.	Kg

## GALVANIZED

VEC02281	2014/68/UE(PED)	5000	8	1650	175	1150	2200	=	=	1950	3118	2"	3"	=	3/4"	3/8"	1120
VEC02282	2014/68/UE(PED)	8000	8	1650	175	1150	1930	2460	3310	1680	4318	2"	3"	3"	3/4"	3/8"	1400
VEC02283	2014/68/UE(PED)	10000	8	1650	175	1150	2200	3150	4250	1950	5118	2"	3"	3"	3/4"	3/8"	1730
VEC01725	2014/68/UE(PED)	4000	12	1450	225	800	2145	=	=	=	2790	2"	3"	=	3/4"	3/8"	835
VEC01726	2014/68/UE(PED)	5000	12	1450	225	800	2745	=	=	=	3390	2"	3"	=	3/4"	3/8"	962
VEC00856	2014/68/UE(PED)	5000	12	1650	175	1150	2200	=	=	1950	3118	2"	3"	=	3/4"	3/8"	1360
VEC01395	2014/68/UE(PED)	6000	12	1450	225	800	3345	=	=	=	3990	2"	3"	=	3/4"	3/8"	1090
VEC01727	2014/68/UE(PED)	8000	12	1650	175	1150	1930	2460	3310	1680	4318	2"	3"	3"	3/4"	3/8"	1730
VEC00982	2014/68/UE(PED)	10000	12	1650	175	1150	2200	3150	4250	1950	5118	2"	3"	3"	3/4"	3/8"	2016
VEC01728	2014/68/UE(PED)	4000	16	1450	225	800	2145	=	=	=	2790	2"	3"	=	3/4"	3/8"	995
VEC01729	2014/68/UE(PED)	5000	16	1450	225	800	2745	=	=	=	3390	2"	3"	=	3/4"	3/8"	1145
VEC01730	2014/68/UE(PED)	6000	16	1450	225	800	3345	=	=	=	3990	2"	3"	=	3/4"	3/8"	1295
VEC02467	2014/68/UE(PED)	10000	16	1650	175	1150	2200	3150	4250	1950	5118	2"	3"	3"	3/4"	3/8"	2585

## ALM

VEC01614	2014/68/UE(PED)	4000	12	1450	225	800	2145	=	=	=	2790	2"	3"	=	3/4"	3/8"	835
VEC01344	2014/68/UE(PED)	5000	12	1450	225	800	2745	=	=	=	3390	2"	3"	=	3/4"	3/8"	962
VEC01124	2014/68/UE(PED)	5000	12	1650	175	1150	2200	=	=	1950	3118	2"	3"	=	3/4"	3/8"	1360
VEC04723	2014/68/UE(PED)	10000	12	1650	175	1150	2200	3150	4250	1950	5118	2"	3"	3"	3/4"	3/8"	2016
VEC02465	2014/68/UE(PED)	4000	16	1450	225	800	2145	=	=	=	2790	2"	3"	=	3/4"	3/8"	995
VEC02466	2014/68/UE(PED)	5000	16	1450	225	800	2745	=	=	=	3390	2"	3"	=	3/4"	3/8"	1145

# HORIZONTAL OVERSIZE

PAINTED - GALVANIZED - ALM

DIRECTIVE 2014/68/UE(PED)  
 OPERATING PRESSURE 12 bar  
 OPERATING TEMPERATURE -20 +80°C

**MATERIAL**

Carbon steel

**FLUID CONTENT**

Compressed air / Nitrogen / Argon / Helium /  
 Oil / Oxygen (group 1 hydrogen excluded)

**FINISHING**

**RAL 5015:** External Ral 5015 blue paint (standard)

**GALVANIZED:** internal and external hot-dip galvanization

**ALM:** External Ral 5015 blue paint (standard) and Internal Ral 5005 ALM paint

**UPON REQUEST**

Inspection ports

100x150 mm handhole

300x400 mm manhole

Flanged connections

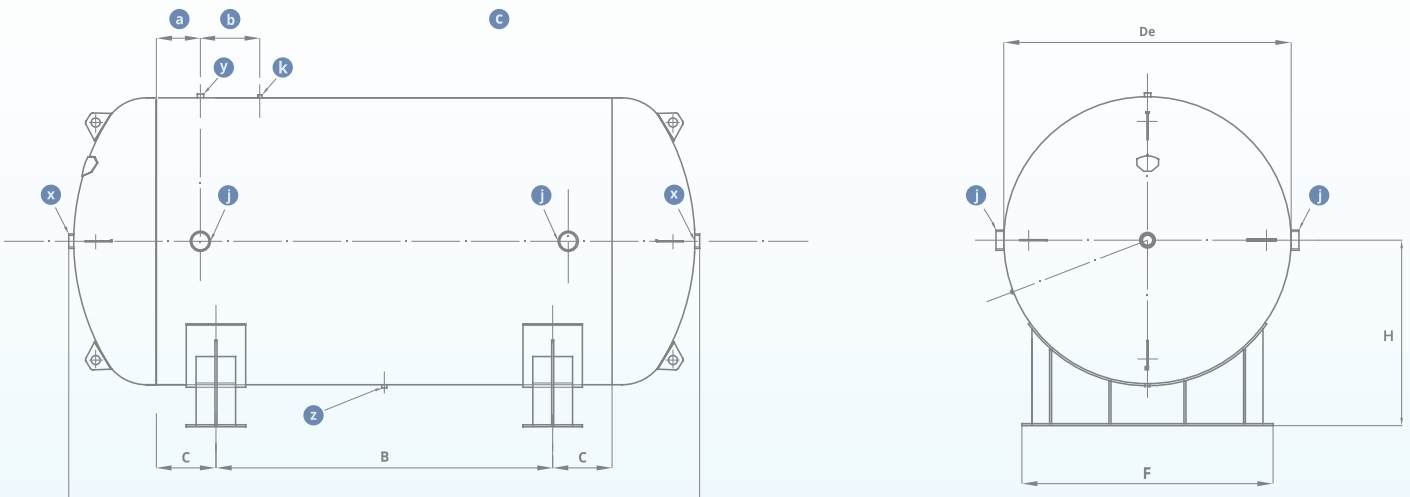

CODE	DIRECTIVE	CAPACITY	OPERATING PRESSURE	De	A	B	C	F	H	a	b	x	y	k	j	z	WEIGHT
		Lt	Bar	mm	mm	mm	mm	mm	mm	mm	mm	inch.	inch.	inch.	inch.	inch.	Kg

**RAL 5015\***

VEC06212	2014/68/UE(PED)	4000	12	1450	2560	1700	300	1267	937	222	300	2"	3/4"	3/8"	3"	1/2"	890
VEC02410	2014/68/UE(PED)	5000	12	1450	3184	1700	300	1267	937	222	300	2"	3/4"	3/8"	3"	1/2"	1060
VEC00772	2014/68/UE(PED)	5000	12	1650	2962	1300	350	1267	1035	300	450	2"	3/4"	3/8"	3"	1/2"	1380
VEC02323	2014/68/UE(PED)	10000	12	1650	4912	2080	1000	1267	1035	450	300	2"	3/4"	3/8"	3"	2"	2240

**GALVANIZED**

VEC03850	2014/68/UE(PED)	4000	12	1450	2560	1700	300	1267	937	222	300	2"	3/4"	3/8"	3"	1/2"	930
VEC04698	2014/68/UE(PED)	5000	12	1450	3184	1700	300	1267	937	222	300	2"	3/4"	3/8"	3"	1/2"	1100
VEC04699	2014/68/UE(PED)	5000	12	1650	2962	1300	350	1267	1035	300	450	2"	3/4"	3/8"	3"	1/2"	1410
VEC04701	2014/68/UE(PED)	10000	12	1650	4912	2080	1000	1267	1035	450	300	2"	3/4"	3/8"	3"	2"	2320

**ALM**

VEC02833	2014/68/UE(PED)	5000	12	1450	3184	1700	300	1267	937	222	300	2"	3/4"	3/8"	3"	1/2"	1060
VEC04700	2014/68/UE(PED)	5000	12	1650	2962	1300	350	1267	1035	300	450	2"	3/4"	3/8"	3"	1/2"	1380

# FLANGED CONNECTIONS AND NON-MANDATORY INSPECTION OPENINGS

The following table is valid only for vessels with operating temperature not less than -20°C and pressure of 11 and 16 bar (from page 25 to page 30)



VOLUME	PRESSURE	DN40	DN50	DN65	DN80	DN90	DN100	DN125	DN150	DN200	DN250	HANDHOLE	MANHOLE
	bar											100x150 mm	300x400 mm
1000	12	•	•	•	•	•	•	•	•	•		•	
1000	16	•	•	•	•	•	•	•	•	•		•	
1500	12	•	•	•	•	•	•	•	•	•		•	•
1500	16	•	•	•	•	•	•	•	•	•		•	•
2000	12	•	•	•	•	•	•	•	•	•		•	•
2000	16	•	•	•	•	•	•	•	•	•		•	•
3000	12	•	•	•	•	•	•	•	•	•		•	•
3000	16	•	•	•	•	•	•	•	•	•	•	•	•
4000	8	•	•	•	•	•	•	•	•	•	•	•	•
4000	12	•	•	•	•	•	•	•	•	•	•	•	•
5000	16	•	•	•	•	•	•	•	•	•	•	•	•
5000	12	•	•	•	•	•	•	•	•	•	•	•	•
5000	16	•	•	•	•	•	•	•	•	•	•	•	•
6000	12	•	•	•	•	•	•	•	•	•	•	•	•
6000	16	•	•	•	•	•	•	•	•	•	•	•	•
8000	8	•	•	•	•	•	•	•	•	•	•	•	•
8000	12	•	•	•	•	•	•	•	•	•	•	•	•
8000	16	•	•	•	•	•	•	•	•	•	•	•	•
10000	8	•	•	•	•	•	•	•	•	•	•	•	•
10000	12	•	•	•	•	•	•	•	•	•	•	•	•
10000	16	•	•	•	•	•	•	•	•	•	•	•	•

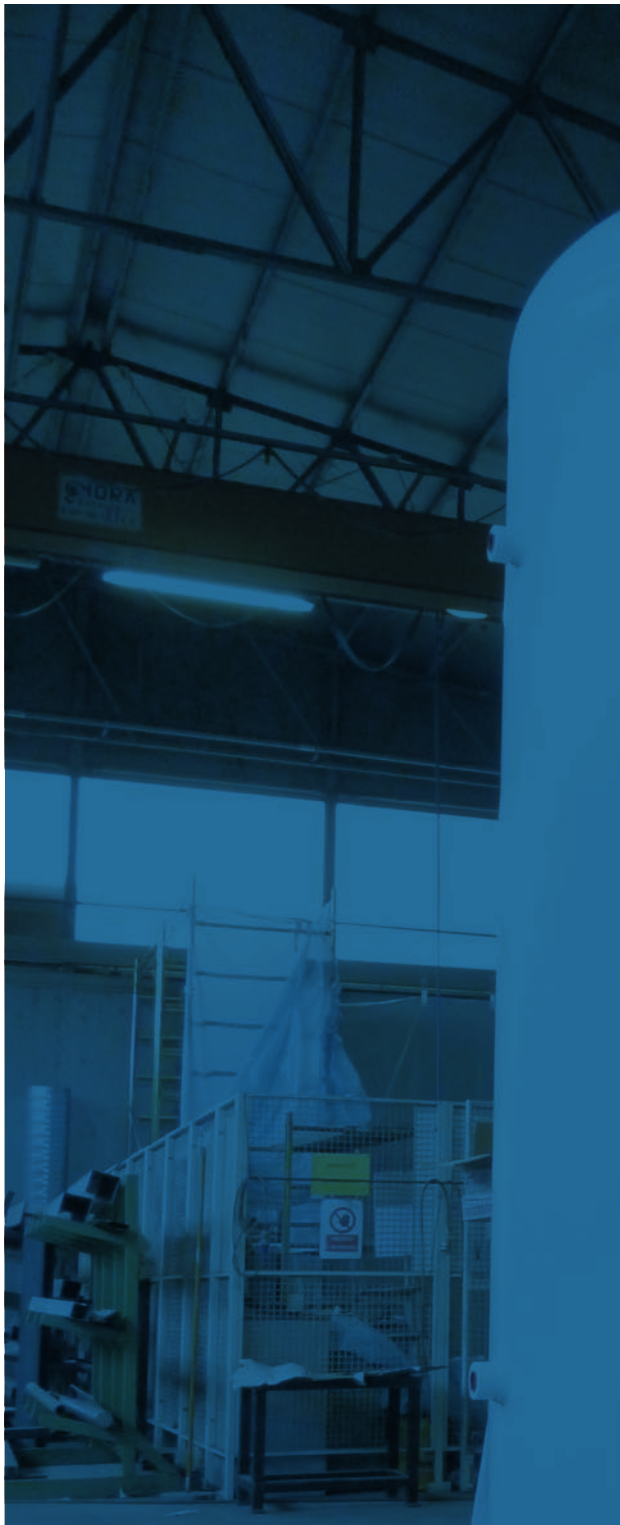

# HIGH PRESSURE VESSELS



## VERTICAL 21 BAR PAINTED - GALVANIZED

DIRECTIVE

OPERATING PRESSURE

OPERATING TEMPERATURE

2014/29/UE(PED) 2014/68/UE(PED)

21 bar 21 bar

\*-20 +120°C -20 +100°C

### 2014/29/UE(PED)

**MATERIAL**

Carbon steel

**FLUID CONTENT**

Compressed air/ Nitrogen (group 2)

**FINISHING**

**RAL 5015:** External Ral 5015 blue paint (standard)

**GALVANIZED:** internal and external hot-dip galvanization

**UPON REQUEST**

ALM version

### 2014/68/UE(PED)

**MATERIAL**

Carbon steel

**FLUID CONTENT**

Compressed air / Nitrogen / Argon / Helium /

Oil / Oxygen (group 1 hydrogen excluded)

**FINISHING**

**RAL 5015:** External Ral 5015 blue paint (standard)

**GALVANIZED:** internal and external hot-dip galvanization

**UPON REQUEST**

ALM version

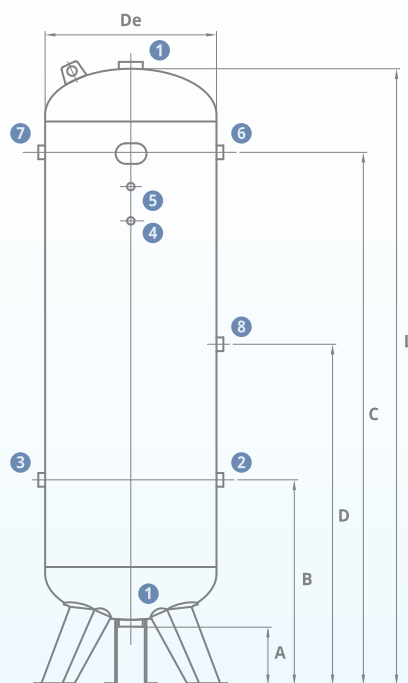
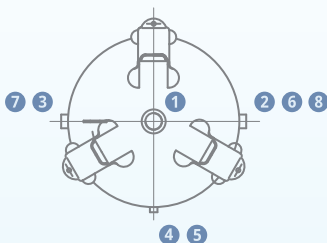

CODE	DIRECTIVE	CAPACITY	OPERATING PRESSURE	De	A	B	C	L	1	2	3	4	5	6	7	WEIGHT
		Lt	Bar	mm	mm	mm	mm	mm	inch.	inch.	inch.	inch.	inch.	inch.	inch.	Kg

### RAL 5015\*

VEC00883	2014/29/UE	*120	21	396	170	395	1065	1430	2"	3/4"	3/4"	1/4"	3/4"	3/4"	=	58
VEC02407	2014/29/UE	*270	21	500	170	600	1305	1790	2"	1"	1"	=	1"	=	=	108
VEC01470	2014/29/UE	*475	21	600	155	785	1665	2055	2"	2"	2"	=	3/8"	2"	2"	220
VEC02275	2014/68/UE(PED)	1000	21	800	145	770	1720	2350	2"	2"	2"	3/8"	3/8"	2"	2"	352
VEC04155	2014/68/UE(PED)	3000	21	1200	140	830	2250	2990	2"	2"	2"	1/2"	1/2"	2"	2"	1250

### GALVANIZED

VEC02438	2009/105/EC	*120	21	396	300	505	1175	1362	2"	3/4"	3/4"	1/4"	3/4"	3/4"	=	58
VEC02433	2009/105/EC	*270	21	500	170	600	1305	1790	2"	1"	1"	=	1"	=	=	110
VEC02434	2009/105/EC	*475	21	600	155	785	1665	2050	2"	2"	2"	=	3/8"	2"	2"	224
VEC02439	2014/68/UE(PED)	1000	21	800	145	770	1720	2350	2"	2"	2"	3/8"	3/8"	2"	2"	352
VEC04156	2014/68/UE(PED)	3000	21	1200	140	830	2250	2990	2"	2"	2"	1/2"	1/2"	2"	2"	1250

## VERTICAL 32 BAR PAINTED - GALVANIZED

### MATERIAL

Carbon steel

### FLUID CONTENT

Compressed air / Nitrogen / Argon / Helium /  
Oil / Oxygen (group 1 hydrogen excluded)

### FINISHING

**RAL 5015:** External Ral 5015 blue paint (standard)

**GALVANIZED:** internal and external hot-dip galvanization

### UPON REQUEST

Inspection ports

100x150 mm handhole

300x400 mm manhole

Flanged connections

ALM version

DIRECTIVE

2014/68/UE(PED)

OPERATING PRESSURE

32 bar

OPERATING TEMPERATURE

-20 +100°C

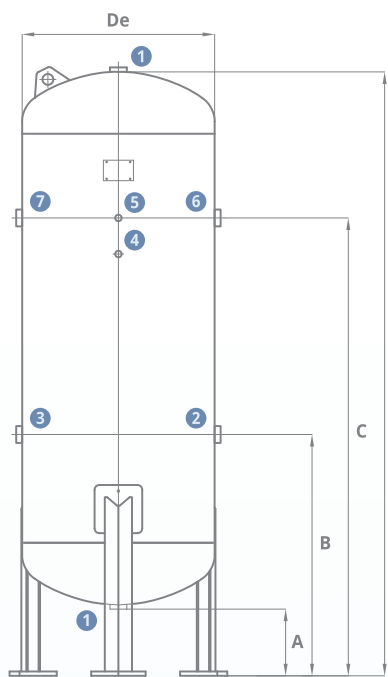

CODE	DIRECTIVE	CAPACITY	OPERATING PRESSURE	De	A	B	C	L	1	2	3	4	5	6	7	WEIGHT
		Lt	Bar	mm	mm	mm	mm	mm	inch.	inch.	inch.	inch.	inch.	inch.	inch.	Kg

### RAL 5015\*

VEC02248	2014/68/UE(PED)	100	32	370	180	355	1055	1213	2"	3/4"	=	3/8"	3/8"	=	3/4"	89
VEC02249	2014/68/UE(PED)	270	32	500	175	599	1304	1648	2"	1"	1"	=	3/8"	1"	1"	192
VEC02250	2014/68/UE(PED)	500	32	600	155	785	1665	2050	2"	2"	2"	1/2"	1/2"	2"	2"	308
VEC02251	2014/68/UE(PED)	1000	32	800	145	770	1720	2350	2"	2"	2"	3/8"	3/8"	2"	2"	470
VEC02252	2014/68/UE(PED)	1500	32	1000	170	680	1780	2305	2"	2"	2"	1/2"	1/2"	2"	2"	665
VEC02253	2014/68/UE(PED)	2000	32	1000	170	770	2185	2740	2"	2"	2"	1/2"	1/2"	2"	2"	1100
VEC02254	2014/68/UE(PED)	3000	32	1200	140	830	2250	2990	2"	2"	2"	1/2"	1/2"	2"	2"	1535
VEC02255	2014/68/UE(PED)	4000	32	1450	225	800	2145	2790	2"	3"	3"	3/4"	3/8"	3"	3"	1950
VEC02256	2014/68/UE(PED)	5000	32	1450	225	800	2745	3390	2"	3"	3"	3/4"	3/8"	3"	3"	2280
VEC02805	2014/68/UE(PED)	6000	32	1450	251	1000	2745	4053	2"	3"	3"	3/4"	3/8"	3"	3"	2700

### GALVANIZED

VEC02440	2014/68/UE(PED)	100	32	370	180	355	1055	1213	2"	3/4"	=	3/8"	3/8"	=	3/4"	89
VEC02441	2014/68/UE(PED)	270	32	500	175	599	1304	1648	2"	1"	1"	=	3/8"	1"	1"	192
VEC02442	2014/68/UE(PED)	500	32	600	155	785	1665	2050	2"	2"	2"	1/2"	1/2"	2"	2"	308
VEC02443	2014/68/UE(PED)	1000	32	800	145	770	1720	2350	2"	2"	2"	3/8"	3/8"	2"	2"	470
VEC02444	2014/68/UE(PED)	1500	32	1000	170	680	1780	2305	2"	2"	2"	1/2"	1/2"	2"	2"	665
VEC02446	2014/68/UE(PED)	2000	32	1000	170	770	2185	2740	2"	2"	2"	1/2"	1/2"	2"	2"	1100
VEC02447	2014/68/UE(PED)	3000	32	1200	140	830	2250	2990	2"	2"	2"	1/2"	1/2"	2"	2"	1535
VEC02448	2014/68/UE(PED)	4000	32	1450	225	800	2145	2790	2"	3"	3"	3/4"	3/8"	3"	3"	1950
VEC02450	2014/68/UE(PED)	5000	32	1450	225	800	2745	3390	2"	3"	3"	3/4"	3/8"	3"	3"	2280
VEC04704	2014/68/UE(PED)	6000	32	1450	251	1000	2745	4053	2"	3"	3"	3/4"	3/8"	3"	3"	2700

# VERTICAL 42 BAR

## PAINTED - GALVANIZED

**DIRECTIVE** 2014/68/UE(PED)  
**OPERATING PRESSURE** 42 bar  
**OPERATING TEMPERATURE** -20 +80°C

**MATERIAL**

Carbon steel

**FLUID CONTENT**

Compressed air / Nitrogen / Argon / Helium / Oil / Oxygen (group 1 hydrogen excluded)

**FINISHING**

**RAL 5015:** External Ral 5015 blue paint (standard)

**GALVANIZED:** internal and external hot-dip galvanization

**UPON REQUEST**

Inspection ports

100x150 mm handhole

300x400 mm manhole

Flanged connections

ALM version

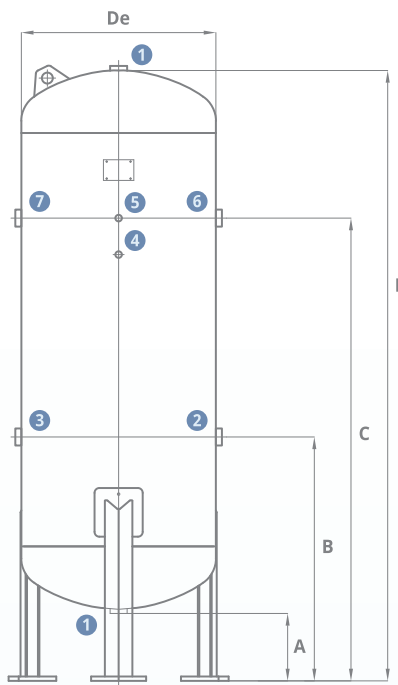

CODE	DIRECTIVE	CAPACITY	OPERATING PRESSURE	De	A	B	C	L	1	2	3	4	5	6	7	WEIGHT
		Lt	Bar	mm	mm	mm	mm	mm	inch.	inch.	inch.	inch.	inch.	inch.	inch.	Kg

### RAL 5015\*

VEC02262	2014/68/UE(PED)	100	42	370	180	355	1055	1213	2"	3/4"	=	3/8"	3/8"	=	3/4"	100
VEC02263	2014/68/UE(PED)	200	42	446	200	430	1255	1587	2"	1"	=	1/2"	3/8"	=	1"	150
VEC02264	2014/68/UE(PED)	270	42	500	175	599	1304	1648	2"	1"	1"	=	3/8"	1"	1"	215
VEC02265	2014/68/UE(PED)	500	42	600	155	785	1665	2050	2"	2"	2"	1/2"	1/2"	2"	2"	355
VEC02266	2014/68/UE(PED)	1000	42	800	145	770	1720	2350	2"	2"	2"	3/8"	3/8"	2"	2"	675
VEC02267	2014/68/UE(PED)	1500	42	1000	170	680	1780	2305	2"	2"	2"	1/2"	1/2"	2"	2"	1100
VEC02268	2014/68/UE(PED)	2000	42	1100	200	770	1970	2490	2"	2"	2"	1/2"	1/2"	2"	2"	1460
VEC02269	2014/68/UE(PED)	3000	42	1200	140	830	2250	2990	2"	2"	2"	1/2"	1/2"	2"	2"	1950
VEC02270	2014/68/UE(PED)	4000	42	1450	225	800	2145	2790	2"	3"	3"	3/4"	3/8"	3"	3"	2540
VEC02271	2014/68/UE(PED)	5000	42	1450	225	800	2745	3390	2"	3"	3"	3/4"	3/8"	3"	3"	2845

### GALVANIZED

VEC02452	2014/68/UE(PED)	100	42	370	180	355	1055	1213	2"	3/4"	=	3/8"	3/8"	=	3/4"	100
VEC02454	2014/68/UE(PED)	200	42	446	200	430	1255	1587	2"	1"	=	1/2"	3/8"	=	1"	150
VEC02455	2014/68/UE(PED)	270	42	500	175	599	1304	1648	2"	1"	1"	=	3/8"	1"	1"	215
VEC02456	2014/68/UE(PED)	500	42	600	155	785	1665	2050	2"	2"	2"	1/2"	1/2"	2"	2"	355
VEC02457	2014/68/UE(PED)	1000	42	800	145	770	1720	2350	2"	2"	2"	3/8"	3/8"	2"	2"	675
VEC02458	2014/68/UE(PED)	1500	42	1000	170	680	1780	2305	2"	2"	2"	1/2"	1/2"	2"	2"	1100
VEC02460	2014/68/UE(PED)	2000	42	1100	200	770	1970	2490	2"	2"	2"	1/2"	1/2"	2"	2"	1460
VEC02461	2014/68/UE(PED)	3000	42	1200	140	830	2250	2990	2"	2"	2"	1/2"	1/2"	2"	2"	1950
VEC02462	2014/68/UE(PED)	4000	42	1450	225	800	2145	2790	2"	3"	3"	3/4"	3/8"	3"	3"	2540
VEC02463	2014/68/UE(PED)	5000	42	1450	225	800	2745	3390	2"	3"	3"	3/4"	3/8"	3"	3"	2845

# ASME VESSELS

## MATERIAL

Carbon steel / Stainless steel

## FLUID CONTENT

Compressed air / Nitrogen / Argon / Helium / Oil / Oxygen (group 1 hydrogen excluded)

## FINISHING

In compliance with customer's requirements or our standard options (for more details see page 8)

DIRECTIVE

ASME SECTION VIII - DIVISION 1

OPERATING PRESSURE

From 145 to 300 PSI

OPERATING TEMPERATURE

-20 +250°F

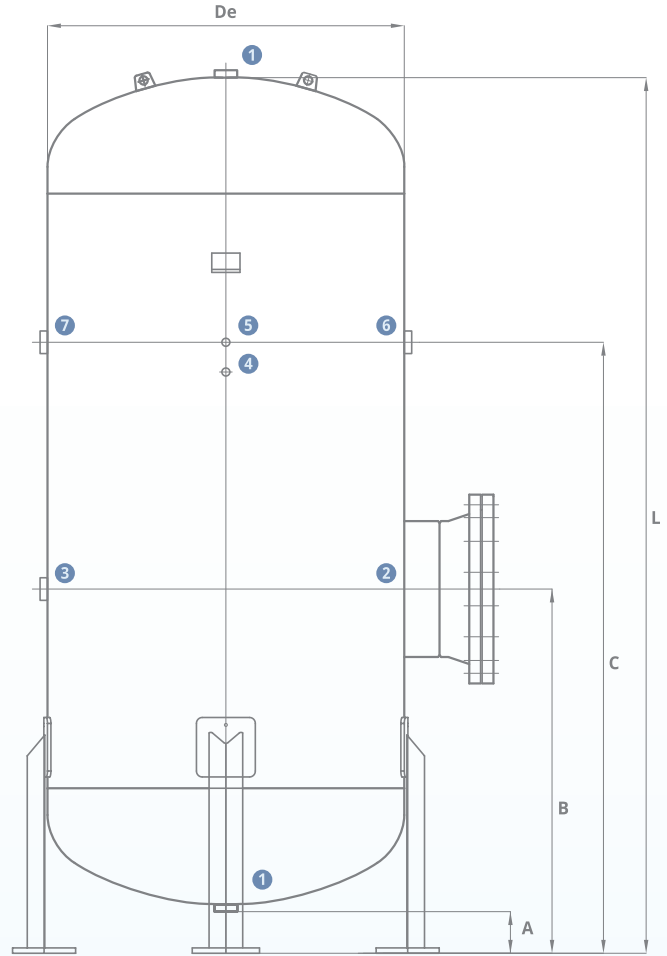

CAPACITY	De	A	B	C	L	1	2	3	4	5	6	7
Lt	mm	mm	mm	mm	mm	inch.	inch.	inch.	inch.	inch.	inch.	inch.

2000	1100	200	770	1970	2490	2"	2"	2"	1/2"	1/2"	2"	2"
3000	1200	140	830	2250	2990	2"	2"	2"	1/2"	1/2"	2"	2"
5000	1450	225	900	2745	3390	2"	3"	3"	3/4"	3/8"	3"	3"

CAPACITY	De	A	B	C	L	1	2	3	4	5	6	7
Lt	mm	mm	mm	mm	mm	inch.	inch.	inch.	inch.	inch.	inch.	inch.

270	500	175	599	1304	1648	2"	1"	1"	=	3/8"	1"	1"
500	600	155	785	1665	2050	2"	2"	2"	1/2"	1/2"	2"	2"
1000	800	145	770	1720	2350	2"	2"	2"	3/8"	3/8"	2"	2"

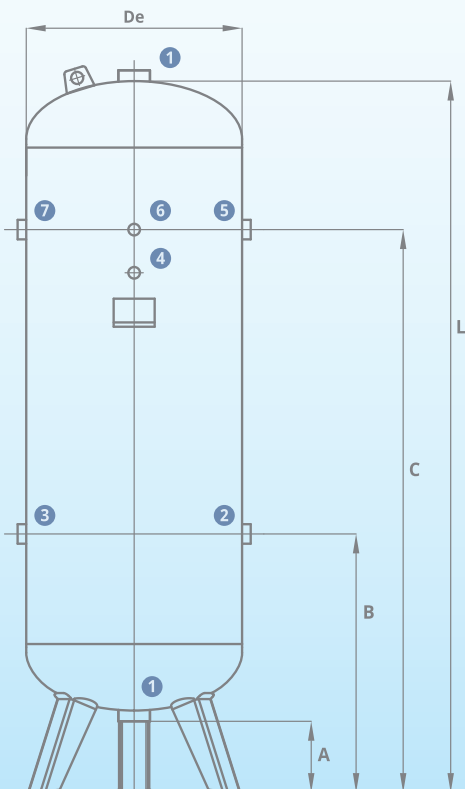

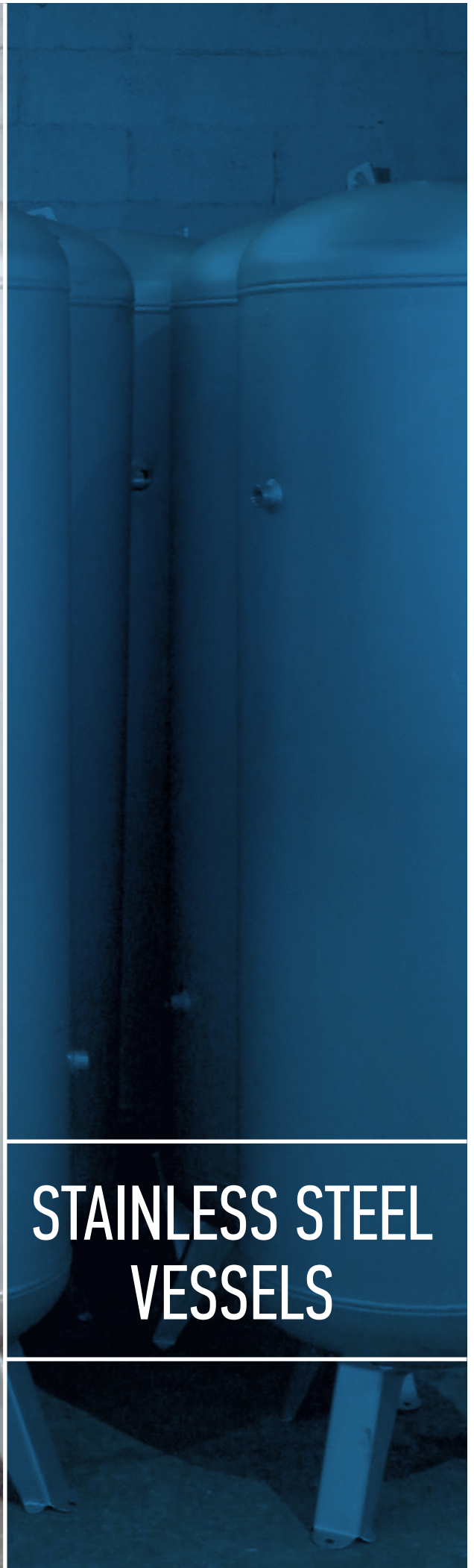

# STAINLESS STEEL VESSELS

# VERTICAL STAINLESS STEEL

**MATERIAL**

Aisi 304/316L Stainless steel

**FLUID CONTENT**

Compressed air / Nitrogen / Compressed air and water (group 2)

**FINISHING**

Internal and external pickling and passivation

**UPON REQUEST**

External electropolishing treatment

DIRECTIVE

2014/68/UE(PED)

OPERATING PRESSURE

11 bar

OPERATING TEMPERATURE

\*-80 +120°C / -55 +80°C

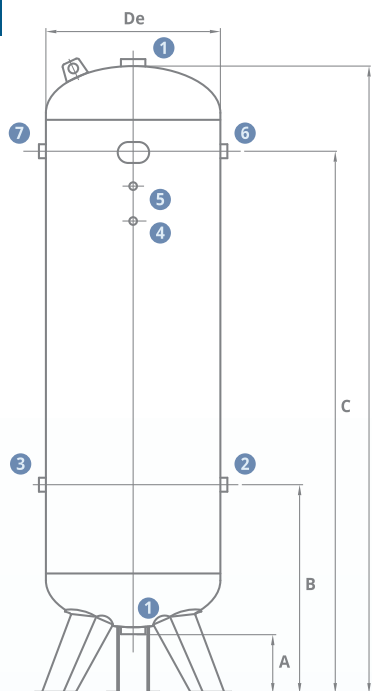
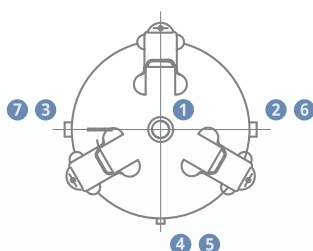

CODE	DIRECTIVE	CAPACITY	OPERATING PRESSURE	De	A	B	C	L	1	2	3	4	5	6	7	WEIGHT
		Lt	Bar	mm	mm	mm	mm	mm	inch.	inch.	inch.	inch.	inch.	inch.	inch.	Kg

## AISI 304

VES03153	2014/68/UE(PED)	*24	11	240	40	161	553	772	1/2"	=	1/2"	=	=	1/2"	=	15
VES01881	2014/68/UE(PED)	*50	11	305	129	276	717	957	1/2"	1/2"	=	=	=	=	1/2"	21
VES01883	2014/68/UE(PED)	*100	11	370	170	358	948	1184	1/2"	=	3/4"	3/8"	3/8"	3/4"	=	32
VES03203	2014/68/UE(PED)	*150	11	446	165	400	897	1277	1/2"	1"	=	1/4"	=	=	1"	49
VES01885	2014/68/UE(PED)	*200	11	446	160	492	1192	1572	1/2"	=	1"	3/8"	3/8"	1"	=	55
VES01887	2014/68/UE(PED)	*270	11	500	165	560	1279	1771	1/2"	1"	1"	3/8"	3/8"	=	1"	69
VES01889	2014/68/UE(PED)	500	11	600	151	763	1633	2061	1/2"	1"	1"	=	3/8"	1"	1"	125
VES01891	97/23/EC (PED)	1000	11	800	140	702	1642	2346	2"	2"	2"	3/8"	3/8"	2"	2"	377
VES02812	2014/68/UE(PED)	1500	11	1000	170	680	1780	2305	2"	2"	2"	1/2"	1/2"	2"	2"	634
VES02773	2014/68/UE(PED)	2000	11	1100	170	740	1940	2460	2"	2"	2"	1/2"	1/2"	2"	2"	810
VES03787	2014/68/UE(PED)	3000	11	1200	150	878	220	2871	2"	2"	2"	1/2"	1/2"	2"	2"	942

## AISI 316L

VES03155	2014/68/UE(PED)	*24	11	240	40	161	553	772	1/2"	=	1/2"	=	=	1/2"	=	15
VES01882	2014/68/UE(PED)	*50	11	305	129	276	717	957	1/2"	1/2"	=	=	=	=	1/2"	21
VES01884	2014/68/UE(PED)	*100	11	370	140	298	948	1106	1/2"	3/4"	=	3/8"	3/8"	=	3/4"	32
VES03204	2014/68/UE(PED)	*150	11	446	165	400	897	1277	1/2"	1"	=	1/4"	=	=	1"	49
VES01886	2014/68/UE(PED)	*200	11	446	160	492	1192	1572	1/2"	=	1"	3/8"	3/8"	1"	=	55
VES01888	2014/68/UE(PED)	*270	11	500	165	560	1279	1771	1/2"	1"	1"	3/8"	3/8"	=	1"	69
VES01890	2014/68/UE(PED)	500	11	600	151	763	1633	2061	1/2"	1"	1"	=	3/8"	1"	1"	125
VES01892	97/23/EC (PED)	1000	11	800	140	702	1642	2346	2"	2"	2"	3/8"	3/8"	2"	2"	377
VES02813	2014/68/UE(PED)	1500	11	1000	170	680	1780	2305	2"	2"	2"	1/2"	1/2"	2"	2"	634
VES02774	2014/68/UE(PED)	2000	11	1100	170	740	1940	2460	2"	2"	2"	1/2"	1/2"	2"	2"	810
VES03788	2014/68/UE(PED)	3000	11	1200	150	878	220	2871	2"	2"	2"	1/2"	1/2"	2"	2"	942

# HORIZONTAL STAINLESS STEEL

**MATERIAL**

Aisi 304/316L Stainless steel

**FLUID CONTENT**

Compressed air / Nitrogen / Compressed air and water (group 2)

**FINISHING**

Internal and external pickling and passivation

**UPON REQUEST**

External electropolishing treatment

DIRECTIVE

2014/68/UE(PED)

OPERATING PRESSURE

11 bar

OPERATING TEMPERATURE

\*-80 +120°C / -55 +80°C

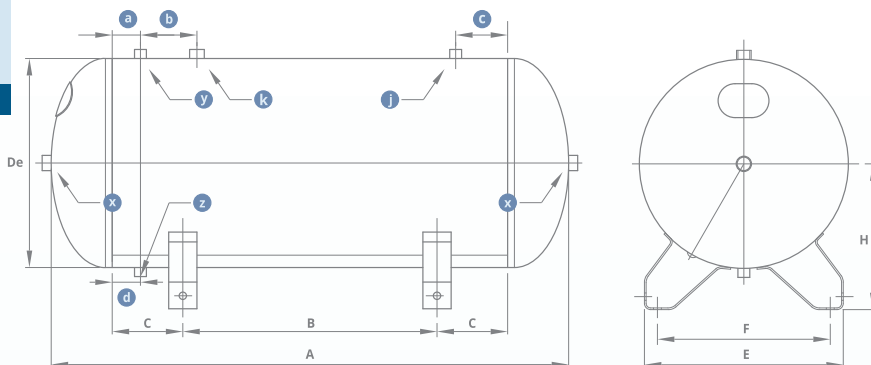

CODE	DIRECTIVE	CAPACITY	OPERATING PRESSURE	De	A	B	C	E	F	H	a	b	c	d	x	y	k	j	z	WEIGHT
		Lt	Bar	mm	mm	mm	mm	mm	mm	mm	mm	mm	mm	mm	inch.	inch.	inch.	inch.	inch.	Kg

## AISI 304

VES04028	2014/68/UE(PED)	*5	11	150	314	130	45	100	160	125	=	=	=	110	1/2"	=	=	=	1/2"	6
VES02586	2014/68/UE(PED)	*10	12	169	506	156	127	200	140	170	127	-	127	205	1/2"	-	1/2"	-	1/2"	8
VES02588	2014/68/UE(PED)	*15	12	196	624	156	172	200	140	178	172	-	172	250	1/2"	-	1/2"	-	1/2"	11
VES02590	2014/68/UE(PED)	*24	11	240	634	192	150	240	180	210	100	-	100	246	1/2"	-	1/2"	-	1/2"	13
VES02592	2014/68/UE(PED)	*50	11	305	784	400	100	285	236	200	100	-	100	300	1/2"	3/8"	3/8"	-	1/2"	21
VES02594	2014/68/UE(PED)	*100	11	370	966	550	100	352	306	256	45	80	45	45	1/2"	3/8"	1/2"	3/8"	3/8"	32
VES03205	2014/68/UE(PED)	*150	11	446	1064	450	175	440	386	288	50	150	50	50	1/2"	3/8"	1/2"	3/8"	1/2"	49
VES02596	2014/68/UE(PED)	*200	11	446	1364	750	175	440	386	288	50	150	50	50	1/2"	3/8"	1/2"	1/2"	3/8"	55
VES02598	2014/68/UE(PED)	*270	11	500	1558	900	175	463	409	315	50	150	120	50	1/2"	3/8"	1"	1/2"	1/2"	69
VES02600	2014/68/UE(PED)	500	11	600	1864	1204	148	530	470	396	60	155	60	60	1/2"	3/8"	1"	1/2"	1/2"	125
VES02602	2014/68/UE(PED)	1000	11	800	2200	1015	345	605	440	500	100	155	60	60	2"	3/4"	1"	1/2"	1/2"	377

## AIS 316L

VES04026	2014/68/UE(PED)	*5	11	150	314	130	45	100	160	125	=	=	=	110	1/2"	=	=	=	1/2"	6
VES02587	2014/68/UE(PED)	*10	12	169	506	156	127	200	140	170	127	-	127	205	1/2"	-	1/2"	-	1/2"	8
VES02589	2014/68/UE(PED)	*15	12	196	624	156	172	200	140	178	172	-	172	250	1/2"	-	1/2"	-	1/2"	11
VES02591	2014/68/UE(PED)	*24	11	240	634	192	150	240	180	210	100	-	100	246	1/2"	-	1/2"	-	1/2"	13
VES02593	2014/68/UE(PED)	*50	11	305	784	400	100	285	236	200	100	-	100	300	1/2"	3/8"	3/8"	-	1/2"	21
VES02595	2014/68/UE(PED)	*100	11	370	966	550	100	352	306	256	45	80	45	45	1/2"	3/8"	1/2"	3/8"	3/8"	32
VES03206	2014/68/UE(PED)	*150	11	446	1064	450	175	440	386	288	50	150	50	50	1/2"	3/8"	1/2"	3/8"	1/2"	49
VES02597	2014/68/UE(PED)	*200	11	446	1364	750	175	440	386	288	50	150	50	50	1/2"	3/8"	1/2"	1/2"	3/8"	55
VES02599	2014/68/UE(PED)	*270	11	500	1558	900	175	463	409	315	50	150	120	50	1/2"	3/8"	1"	1/2"	1/2"	69
VES02601	2014/68/UE(PED)	500	11	600	1864	1204	148	530	470	396	60	155	60	60	1/2"	3/8"	1"	1/2"	1/2"	125
VES02603	2014/68/UE(PED)	1000	11	800	2200	1015	345	605	440	500	100	155	60	60	2"	3/4"	1"	1/2"	1/2"	377

# ACCESSORIES



PRESSURE GAUGE  
63 MM G 1/4"

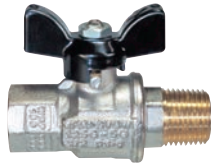

BALL TAP  
G 1/2" G 1"



PRESSURE GAUGE FLANGE  
G 3/8"



SAFETY VALVE  
G 1/2" CONNECTION



SAFETY VALVE  
G 1/2" CONNECTION



SAFETY VALVE  
G 1" CONNECTION



SAFETY VALVE  
G 1" CONNECTION



SAFETY VALVE  
G 13/4" CONNECTION

REFERENCE	QUANTITY	DESCRIPTION	MATERIAL	DIRECTIVE	CALIBRATION	DRAIN FLOW RATE
KIT00024	1 1	SAFETY VALVE G 1/2" PRESSURE GAUGE Ø 63 MM G 1/4"	BRASS	2014/68/UE (PED)	11 BAR 11 BAR	7237 LT/MIN
KIT00100	1 1 1	SAFETY VALVE G 3/4" PRESSURE GAUGE Ø 63 MM G 1/4" BALL TAP G 1/2"	BRASS	2014/68/UE (PED)	11 BAR 11 BAR	17767 LT/MIN
KIT00093	1 1 1	SAFETY VALVE G 1" PRESSURE GAUGE Ø 63 MM G 1/4" BALL TAP G 1"	BRASS	2014/68/UE (PED)	11 BAR 11 BAR	38221 LT/MIN
KIT00026	1 1 1	SAFETY VALVE G 3/4" PRESSURE GAUGE Ø 63 MM G 1/4" BALL TAP G 1/2"	BRASS	2014/68/UE (PED)	12 BAR 12 BAR	19184 LT/MIN
KIT00028	1 1 1	SAFETY VALVE G 1" PRESSURE GAUGE Ø 63 MM G 1/4" BALL TAP G 1"	BRASS	2014/68/UE (PED)	12 BAR 12 BAR	41407 LT/MIN
KIT00114	1 1	SAFETY VALVE G 1/2" PRESSURE GAUGE Ø 63 MM G 1/4"	BRASS	2014/68/UE (PED)	15 BAR 15 BAR	9650 LT/MIN
KIT00031	1 1	SAFETY VALVE G 1/2" PRESSURE GAUGE Ø 63 MM G 1/4"	BRASS	2014/68/UE (PED)	16 BAR 16 BAR	10253 LT/MIN
KIT00088	1 1	SAFETY VALVE G 3/4" PRESSURE GAUGE Ø 63 MM G 1/4"	BRASS	2014/68/UE (PED)	16 BAR 16 BAR	24851 LT/MIN
KIT00023	1 1	SAFETY VALVE G 1" PRESSURE GAUGE Ø 63 MM G 1/4"	BRASS	2014/68/UE (PED)	16 BAR 16 BAR	54147 LT/MIN
KIT00040	1 1	SAFETY VALVE G 1/2" PRESSURE GAUGE Ø 63 MM G 1/4"	BRASS	2014/68/UE (PED)	21 BAR 25 BAR	16517 LT/MIN
KIT00105	1 1	"SAFETY VALVE G 1/2" PRESSURE GAUGE Ø 63 MM G 1/4"	BRASS	2014/68/UE (PED)	32 BAR 32 BAR	24811 LT/MIN
KIT00106	1 1	SAFETY VALVE G 1" PRESSURE GAUGE Ø 63 MM G 1/4"	BRASS	2014/68/UE (PED)	32 BAR 32 BAR	103110 LT/MIN
KIT00107	1 1	SAFETY VALVE G 1/2" PRESSURE GAUGE Ø 63 MM G 1/4"	BRASS	2014/68/UE (PED)	42 BAR 42 BAR	32350 LT/MIN
KIT00087	1 1	SAFETY VALVE G 1" PRESSURE GAUGE Ø 63 MM G 1/4"	BRASS	2014/68/UE (PED)	42 BAR 42 BAR	134442 LT/MIN
KIT00030	1 1	SAFETY VALVE G 1/2" PRESSURE GAUGE Ø 63 MM G 1/4"	BRASS	2014/68/UE (PED)	8 BAR 8 BAR	5419 LT/MIN
KIT00102	1 1	SAFETY VALVE G 1" PRESSURE GAUGE Ø 63 MM G 1/4"	BRASS	2014/68/UE (PED)	8 BAR 8 BAR	28666 LT/MIN
KIT00044	1 1	SAFETY VALVE G 1/2" (STAINLESS STEEL) PRESSURE GAUGE Ø 63 MM G 1/4"	316L STAINLESS STEEL	2014/68/UE (PED)	11 BAR 11 BAR	8983 LT/MIN
KIT00103	1 1	SAFETY VALVE G 1" (STAINLESS STEEL) PRESSURE GAUGE Ø 63 MM G 1/4"	316L STAINLESS STEEL	CE PED 97/23	11 BAR 11 BAR	7237 LT/MIN
ART00122	1	PRESSURE GAUGE FLANGE G 3/8"	BRASS	=====	=====	



# INSTALLATIONS

## COMPRESSED AIR PLAN EXAMPLE

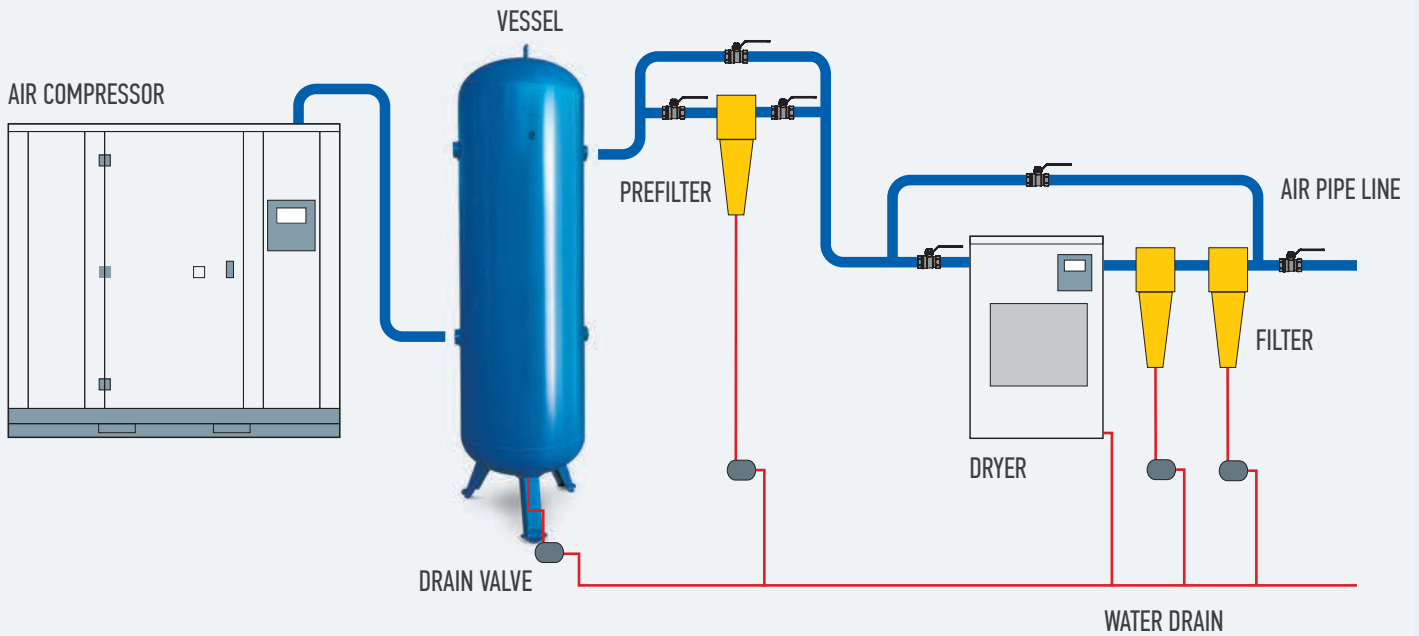

## AUTOCLAVE PLANT EXAMPLE

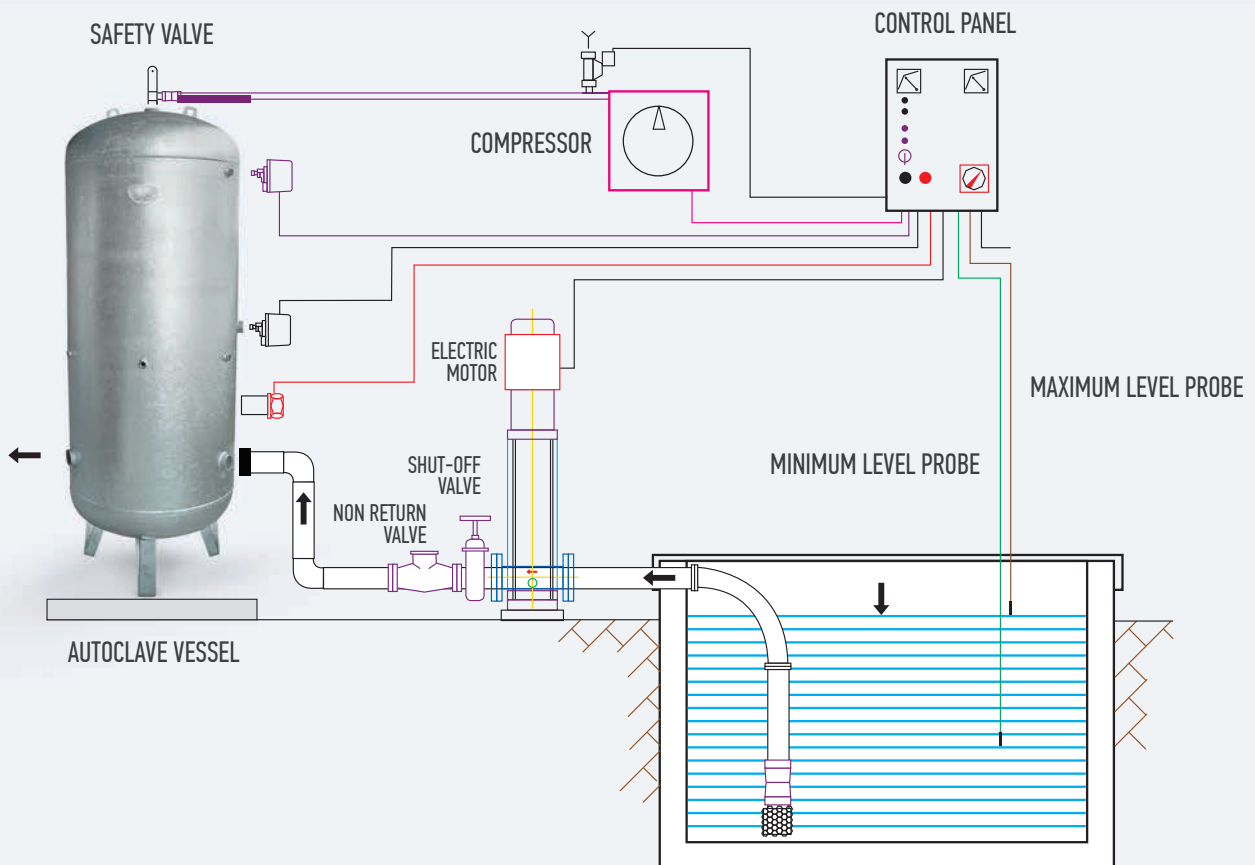

# SPECIAL PROJECTS

We closely cooperate with our customers during activities of research and development, supporting their quality and specification requirements with a view to ideal product integration in the system where our vessels are to be installed.

We ensure the utmost care and attention to customized design projects in accordance with customer specifications and instructions, e.g., special flange mounting requirements, manual welding or customized carpentries.

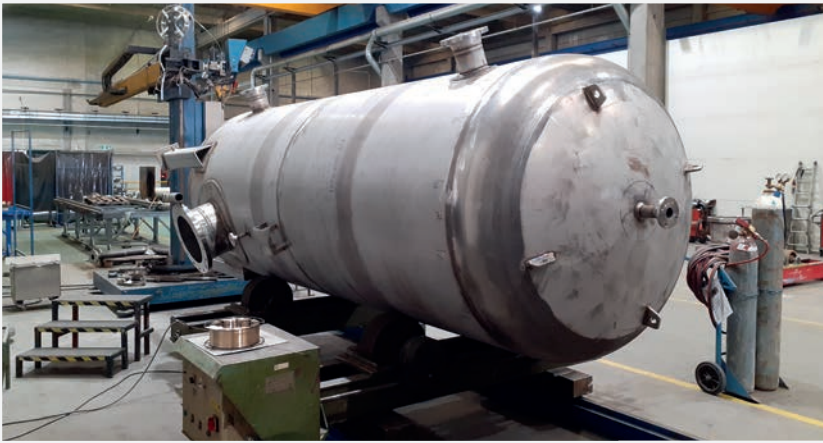

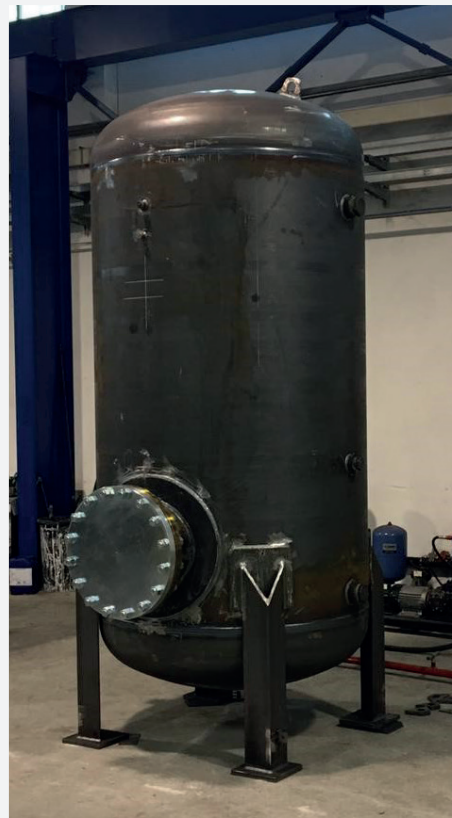



#### BAGLIONI HEADQUARTERS

Via Dante Alighieri, 8  
28060 San Pietro Mosezzo, Novara Italy  
Phone +39 0321 485211  
Fax +39 0321 53571

[baglionispa.com](http://baglionispa.com)