

# MODULAR PSA NITROGEN GENERATORS

## NIMOS NM1

Performance at inlet pressure: **7,5 bar (g)**

	LP					HP				
	95 %	97 %	98 %	99 %	99,5 %	99,9 %	99,95 %	99,99 %	99,995 %	99,999 %
<b>Nitrogen purity rate</b>	95 %	97 %	98 %	99 %	99,5 %	99,9 %	99,95 %	99,99 %	99,995 %	99,999 %
<b>Residual oxygen</b>	5 %	3 %	2 %	1 %	0,5 %	0,1 %	500 PPM	100 PPM	50 PPM	10 PPM
<b>Flow m<sup>3</sup>/h <sup>(1)</sup> FND</b>	<b>8,0</b>	<b>6,1</b>	<b>5,1</b>	<b>4,5</b>	<b>3,5</b>	<b>2,2</b>	<b>2,0</b>	<b>1,4</b>	<b>1,1</b>	<b>0,7</b>
<b>Feed Air m<sup>3</sup>/h FAD</b>	17,8	15,5	14,3	13,6	12,1	10,5	9,0	8,7	8,3	7,9

(1) Flow rates at standard atmospheric conditions (20°C/1000 mbar/0% RH)

Performance at inlet pressure: **9,5 bar (g)**

	LP					HP				
	95 %	97 %	98 %	99 %	99,5 %	99,9 %	99,95 %	99,99 %	99,995 %	99,999 %
<b>Nitrogen purity rate</b>	95 %	97 %	98 %	99 %	99,5 %	99,9 %	99,95 %	99,99 %	99,995 %	99,999 %
<b>Residual oxygen</b>	5 %	3 %	2 %	1 %	0,5 %	0,1 %	500 PPM	100 PPM	50 PPM	10 PPM
<b>Flow m<sup>3</sup>/h <sup>(1)</sup> FND</b>	<b>9,9</b>	<b>7,5</b>	<b>6,3</b>	<b>5,5</b>	<b>4,3</b>	<b>2,7</b>	<b>2,4</b>	<b>1,7</b>	<b>1,3</b>	<b>0,8</b>
<b>Feed Air m<sup>3</sup>/h FAD</b>	22,0	19,2	17,7	16,8	15,0	13,0	11,1	10,7	10,2	9,7

(1) Flow rates at standard atmospheric conditions (20°C/1000 mbar/0% RH)

### Feed Air Requirements

Quality:	Class 1-4-1 ISO 8573.1 Solid < 0,1 µm Dew point < +3°C Oil < 0,01 mg/m <sup>3</sup>
Pressure:	6 - 10 bar (g)
Temperature:	+5..... +45°C

<sup>(2)</sup>Dew point at atmospheric pressure.

<sup>(3)</sup>Necessary for guarantee performance of the nitrogen generator.

### Nitrogen Specifications

Outlet pressure:	0-9 bar(g)
Dew point: <sup>(2)</sup>	< 40°C
Nitrogen process tank: <sup>(3)</sup>	10 lt

### Power Requirements

Power Supply:	230 V / 50 - 60 Hz
Power Consumption:	max. 0,5 kW



**Dimensions & Weight**

L:	460 mm
P:	861 mm
H:	1363 mm
Weight:	170 kg

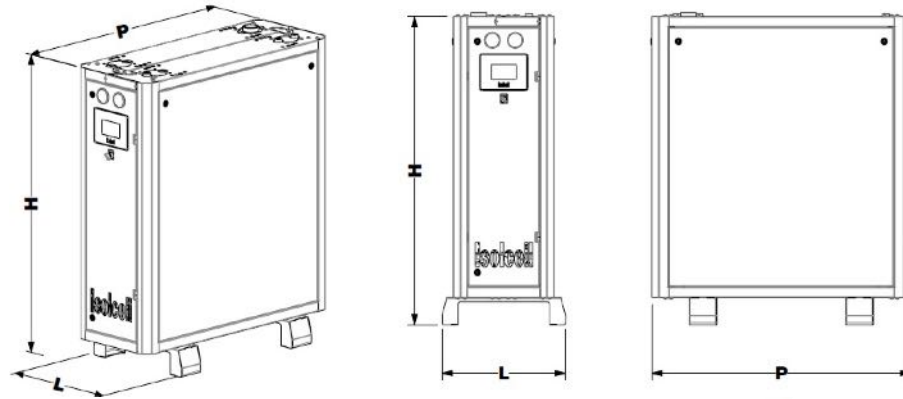

**Connections**

Air inlet:	G1/2"
N <sub>2</sub> outlet:	G1/2"
O <sub>2</sub> enriched air outlet:	G2"

**STANDARD EQUIPMENT AND OPTIONS**

- = standard equipment
- = option

**Control panel**

5" Touch Screen display	●
-------------------------	---

**Purity monitoring and control**

O <sub>2</sub> Electrochemical Sensor 0-25 %	○
O <sub>2</sub> Zirconium Sensor 0-25 %	○
O <sub>2</sub> Zirconium Sensor 10-1000 ppm	○
Dew point sensor with indication on display	○
Flow meter with indication on display	○

**Valves and accessories**

Back pressure control valve kit	○
Compressed air pressure sensor	○
Nitrogen buffer pressure sensor	●
Process tank pressure sensor	○
Exhaust silencer	●
Super exhaust silencer extern mounted	○

**Logging and data handling**

Analog output 4-20mA (O <sub>2</sub> level)	●
Modbus RTU	●
Modbus RS485/USB serial converter	○
Profibus connection convert	○
Canbus connection convert	○
Webserver	○
Digital remote control	●
Extern alarm digital input	●

**Accessories**

Process tank (Integrated)	●
---------------------------	---

# MODULAR PSA NITROGEN GENERATORS

## NIMOS NM2

Performance at inlet pressure: **7,5 bar (g)**

	LP					HP				
<b>Nitrogen purity rate</b>	95 %	97 %	98 %	99 %	99,5 %	99,9 %	99,95 %	99,99 %	99,995 %	99,999 %
<b>Residual oxygen</b>	5 %	3 %	2 %	1 %	0,5 %	0,1 %	500 PPM	100 PPM	50 PPM	10 PPM
<b>Flow m<sup>3</sup>/h <sup>(1)</sup> FND</b>	<b>15,9</b>	<b>12,2</b>	<b>10,3</b>	<b>8,9</b>	<b>7,0</b>	<b>4,4</b>	<b>4,0</b>	<b>2,8</b>	<b>2,2</b>	<b>1,5</b>
<b>Feed Air m<sup>3</sup>/h FAD</b>	35,6	31,0	28,6	27,2	24,3	20,9	18,0	17,3	16,6	15,8

(1) Flow rates at standard atmospheric conditions (20°C/1000 mbar/0% RH)

Performance at inlet pressure: **9,5 bar (g)**

	LP					HP				
<b>Nitrogen purity rate</b>	95 %	97 %	98 %	99 %	99,5 %	99,9 %	99,95 %	99,99 %	99,995 %	99,999 %
<b>Residual oxygen</b>	5 %	3 %	2 %	1 %	0,5 %	0,1 %	500 PPM	100 PPM	50 PPM	10 PPM
<b>Flow m<sup>3</sup>/h <sup>(1)</sup> FND</b>	<b>20,0</b>	<b>15,2</b>	<b>12,7</b>	<b>10,8</b>	<b>8,4</b>	<b>5,5</b>	<b>5,0</b>	<b>3,5</b>	<b>2,8</b>	<b>1,6</b>
<b>Feed Air m<sup>3</sup>/h FAD</b>	44,0	38,1	35,1	33,3	29,6	26,5	26,0	21,0	20,2	19,0

(1) Flow rates at standard atmospheric conditions (20°C/1000 mbar/0% RH)

### Feed Air Requirements

Quality:	Class 1-4-1 ISO 8573.1 Solid < 0,1 µm Dew point < +3°C Oil < 0,01 mg/m <sup>3</sup>
Pressure:	6 - 10 bar (g)
Temperature:	+5..... +45°C

(2) Dew point at atmospheric pressure.

(3) Necessary for guarantee performance of the nitrogen generator.

### Nitrogen Specifications

Outlet pressure:	0-9 bar(g)
Dew point:(2)	< 40°C
Nitrogen process tank:(3)	10 lt

### Power Requirements

Power Supply:	230 V / 50 - 60 Hz
Power Consumption:	max. 0,5 kW



**Dimensions & Weight**

L:	460 mm
P:	861 mm
H:	1363 mm
Weight:	210 kg

**Connections**

Air inlet:	G½"
N <sub>2</sub> outlet:	G½"
O <sub>2</sub> enriched air outlet:	G2"

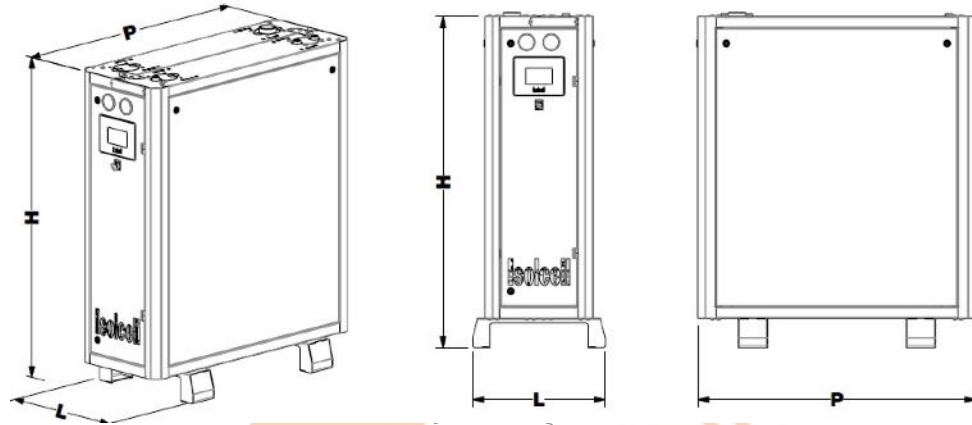

**STANDARD EQUIPMENT AND OPTIONS**

- = standard equipment
- = option

**Control panel**

4 line display	●
----------------	---

**Purity monitoring and control**

O <sub>2</sub> Electrochemical Sensor 0-25 %	○
O <sub>2</sub> Zirconium Sensor 0-25 %	○
O <sub>2</sub> Zirconium Sensor 10-1000 ppm	○
Dew point sensor with indication on display	○
Flow meter with indication on display	○

**Valves and accessories**

Back pressure control valve kit	○
Compressed air pressure sensor	○
Nitrogen buffer pressure sensor	●
Process tank pressure sensor	○
Exhaust silencer	●
Super exhaust silencer extern mounted	○

**Logging and data handling**

Analog output 4-20mA (O <sub>2</sub> level)	●
Modbus RTU	●
Modbus RS485/USB serial converter	○
Profibus connection convert	○
Canbus connection convert	○
Webserver	○
Digital remote control	●
Extern alarm digital input	●

**Necessary accessory**

Process tank (Integrated)	●
---------------------------	---

# MODULAR PSA NITROGEN GENERATORS

## NIMOS NM3

Performance at inlet pressure: **7,5 bar (g)**

	LP					HP				
	95 %	97 %	98 %	99 %	99,5 %	99,9 %	99,95 %	99,99 %	99,995 %	99,999 %
<b>Nitrogen purity rate</b>	95 %	97 %	98 %	99 %	99,5 %	99,9 %	99,95 %	99,99 %	99,995 %	99,999 %
<b>Residual oxygen</b>	5 %	3 %	2 %	1 %	0,5 %	0,1 %	500 PPM	100 PPM	50 PPM	10 PPM
<b>Flow m<sup>3</sup>/h <sup>(1)</sup> FND</b>	<b>23,9</b>	<b>18,3</b>	<b>15,4</b>	<b>13,4</b>	<b>10,5</b>	<b>6,6</b>	<b>6,0</b>	<b>4,2</b>	<b>3,3</b>	<b>2,2</b>
<b>Feed Air m<sup>3</sup>/h FAD</b>	53,3	46,5	42,9	40,7	36,4	31,4	27,1	26,0	24,9	23,7

(1) Flow rates at standard atmospheric conditions (20°C/1000 mbar/0% RH)

Performance at inlet pressure: **9,5 bar (g)**

	LP					HP				
	95 %	97 %	98 %	99 %	99,5 %	99,9 %	99,95 %	99,99 %	99,995 %	99,999 %
<b>Nitrogen purity rate</b>	95 %	97 %	98 %	99 %	99,5 %	99,9 %	99,95 %	99,99 %	99,995 %	99,999 %
<b>Residual oxygen</b>	5 %	3 %	2 %	1 %	0,5 %	0,1 %	500 PPM	100 PPM	50 PPM	10 PPM
<b>Flow m<sup>3</sup>/h <sup>(1)</sup> FND</b>	<b>30,1</b>	<b>22,7</b>	<b>19,0</b>	<b>16,2</b>	<b>12,6</b>	<b>8,2</b>	<b>7,5</b>	<b>5,3</b>	<b>4,2</b>	<b>2,4</b>
<b>Feed Air m<sup>3</sup>/h FAD</b>	66,0	57,2	57,2	49,9	44,4	39,8	39,0	31,5	30,3	28,5

(1) Flow rates at standard atmospheric conditions (20°C/1000 mbar/0% RH)

### Feed Air Requirements

Quality:	Class 1-4-1 ISO 8573.1 Solid < 0,1 µm Dew point < +3°C Oil < 0,01 mg/m <sup>3</sup>
Pressure:	6 - 10 bar (g)
Temperature:	+5..... +45°C

<sup>(2)</sup> Dew point at atmospheric pressure.

<sup>(3)</sup> Necessary for guarantee performance of the nitrogen generator.

### Nitrogen Specifications

Outlet pressure:	0-9 bar(g)
Dew point: <sup>(2)</sup>	< 40°C
Nitrogen process tank: <sup>(3)</sup>	25 lt

### Power Requirements

Power Supply:	230 V / 50 - 60 Hz
Power Consumption:	max. 0,5 kW



**Dimensions & Weight**

L:	460 mm
P:	1133 mm
H:	1500 mm
Weight:	260 kg

**Connections**

Air inlet:	G1/2"
N <sub>2</sub> outlet:	G1/2"
O <sub>2</sub> enriched air outlet:	G2"

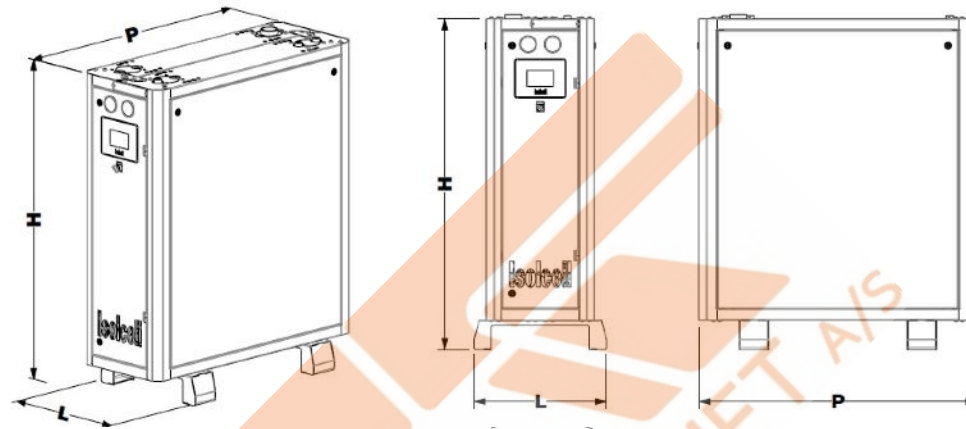

**STANDARD EQUIPMENT AND OPTIONS**

- = standard equipment
- = option

**Control panel**

4 line display	●
----------------	---

**Purity monitoring and control**

O <sub>2</sub> Electrochemical Sensor 0-25 %	○
O <sub>2</sub> Zirconium Sensor 0-25 %	○
O <sub>2</sub> Zirconium Sensor 10-1000 ppm	○
Dew point sensor with indication on display	○
Flow meter with indication on display	○

**Valves and accessories**

Back pressure control valve kit	○
Compressed air pressure sensor	○
Nitrogen buffer pressure sensor	●
Process tank pressure sensor	○
Exhaust silencer	●
Super exhaust silencer extern mounted	○

**Logging and data handling**

Analog output 4-20mA (O <sub>2</sub> level)	●
Modbus RTU	●
Modbus RS485/USB serial converter	○
Profibus connection convert	○
Canbus connection convert	○
Webserver	○
Digital remote control	○
Extern alarm digital input	●

**Necessary accessory**

Process tank (Intrgrated)	●
---------------------------	---

# MODULAR PSA NITROGEN GENERATORS

## NIMOS NM4

Performance at inlet pressure: **7,5 bar (g)**

	LP					HP				
	95 %	97 %	98 %	99 %	99,5 %	99,9 %	99,95 %	99,99 %	99,995 %	99,999 %
<b>Nitrogen purity rate</b>	95 %	97 %	98 %	99 %	99,5 %	99,9 %	99,95 %	99,99 %	99,995 %	99,999 %
<b>Residual oxygen</b>	5 %	3 %	2 %	1 %	0,5 %	0,1 %	500 PPM	100 PPM	50 PPM	10 PPM
<b>Flow m<sup>3</sup>/h <sup>(1)</sup> FND</b>	<b>29,4</b>	<b>23,2</b>	<b>20,0</b>	<b>17,5</b>	<b>14,7</b>	<b>10,4</b>	<b>8,0</b>	<b>5,6</b>	<b>4,4</b>	<b>3,7</b>
<b>Feed Air m<sup>3</sup>/h FAD</b>	59,6	52,9	49,6	46,9	43,9	38,2	36,1	34,6	33,3	32,9

(1) Flow rates at standard atmospheric conditions (20°C/1000 mbar/0% RH)

Performance at inlet pressure: **9,5 bar (g)**

	LP					HP				
	95 %	97 %	98 %	99 %	99,5 %	99,9 %	99,95 %	99,99 %	99,995 %	99,999 %
<b>Nitrogen purity rate</b>	95 %	97 %	98 %	99 %	99,5 %	99,9 %	99,95 %	99,99 %	99,995 %	99,999 %
<b>Residual oxygen</b>	5 %	3 %	2 %	1 %	0,5 %	0,1 %	500 PPM	100 PPM	50 PPM	10 PPM
<b>Flow m<sup>3</sup>/h <sup>(1)</sup> FND</b>	<b>35,7</b>	<b>27,8</b>	<b>23,9</b>	<b>20,5</b>	<b>17,4</b>	<b>13,1</b>	<b>10,1</b>	<b>7,0</b>	<b>5,5</b>	<b>3,9</b>
<b>Feed Air m<sup>3</sup>/h FAD</b>	73,6	64,0	59,2	55,0	51,5	55,1	52,0	42,0	40,4	40,0

(1) Flow rates at standard atmospheric conditions (20°C/1000 mbar/0% RH)

### Feed Air Requirements

Quality:	Class 1-4-1 ISO 8573.1 Solid < 0,1 µm Dew point < +3°C Oil < 0,01 mg/m <sup>3</sup>
Pressure:	6 - 10 bar (g)
Temperature:	0..... +45°C

<sup>(2)</sup> Dew point at atmospheric pressure.

<sup>(3)</sup> Necessary for guarantee performance of the nitrogen generator.

### Nitrogen Specifications

Outlet pressure:	0-9 bar(g)
Dew point: <sup>(2)</sup>	< 40°C
Nitrogen process tank: <sup>(3)</sup>	25 lt

### Power Requirements

Power Supply:	230 V / 50 - 60 Hz
Power Consumption:	max. 0,5 kW



**Dimensions & Weight**

L:	460 mm
P:	1133 mm
H:	1500 mm
Weight:	300 kg

**Connections**

Air inlet:	G1/2"
N <sub>2</sub> outlet:	G1/2"
O <sub>2</sub> enriched air outlet:	G2"

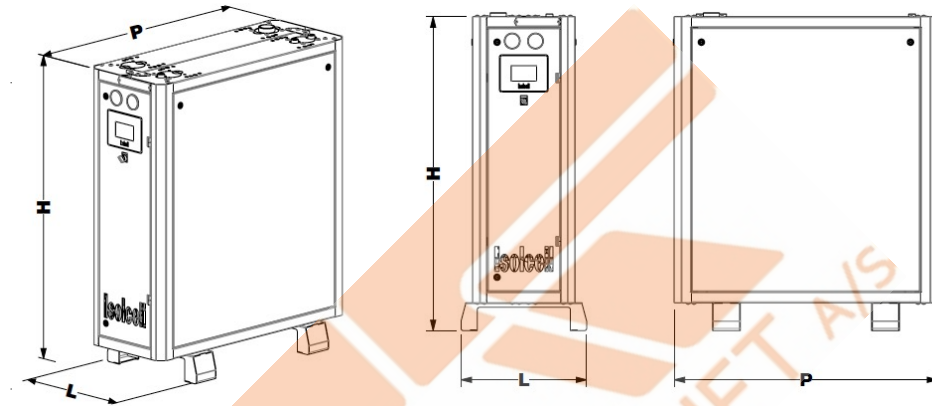

**STANDARD EQUIPMENT AND OPTIONS**

- = standard equipment
- = option

**Control panel**

4 line display	●
----------------	---

**Purity monitoring and control**

O <sub>2</sub> Electrochemical Sensor 0-25 %	○
O <sub>2</sub> Zirconium Sensor 0-25 %	○
O <sub>2</sub> Zirconium Sensor 10-1000 ppm	○
Dew point sensor with indication on display	○
Flow meter with indication on display	○

**Valves and accessories**

Back pressure control valve kit	○
Compressed air pressure sensor	○
Nitrogen buffer pressure sensor	●
Process tank pressure sensor	○
Exhaust silencer	●
Super exhaust silencer extern mounted	○

**Logging and data handling**

Analog output 4-20mA (O <sub>2</sub> level)	●
Modbus RTU	●
Modbus RS485/USB serial converter	○
Profibus connection convert	○
Canbus connection convert	○
Webserver	○
Digital remote control	●
Extern alarm digital input	●

**Necessary accessory**

Process tank (Integrated)	●
---------------------------	---