

MODULAR PSA NITROGEN GENERATORS

NIMOS S3

Performance at inlet pressure: **7,5 bar (g)**

	LP					HP				
Nitrogen purity rate	95 %	97 %	98 %	99 %	99,5 %	99,9 %	99,95 %	99,99 %	99,995 %	99,999 %
Residual oxygen	5 %	3 %	2 %	1 %	0,5 %	0,1 %	500 PPM	100 PPM	50 PPM	10 PPM
Flow m³/h ⁽¹⁾ FND	43,2	34,5	29,6	23,6	19,3	12,7	10,6	7,1	6,0	4,0
Feed Air m³/h FAD	87,7	76,3	70,1	62,7	57,5	49,4	46,6	41,5	40,0	39,5

(1) Flow rates at standard atmospheric conditions (20°C/1000 mbar/0% RH) - Nitrogen outlet pressure 6bar(g) - Performance data ± 5%

Performance at inlet pressure: **9,5 bar (g)**

	LP					HP				
Nitrogen purity rate	95 %	97 %	98 %	99 %	99,5 %	99,9 %	99,95 %	99,99 %	99,995 %	99,999 %
Residual oxygen	5 %	3 %	2 %	1 %	0,5 %	0,1 %	500 PPM	100 PPM	50 PPM	10 PPM
Flow m³/h ⁽¹⁾ FND	51,8	41,4	35,5	28,3	23,2	15,2	12,8	8,6	7,2	4,8
Feed Air m³/h FAD	106,8	93,0	85,4	76,3	70,1	60,2	56,8	50,6	48,8	48,1

(1) Flow rates at standard atmospheric conditions (20°C/1000 mbar/0% RH) - Nitrogen outlet pressure 6bar(g) - Performance data ± 5%

Feed Air Requirements

Quality:	Class 1-4-1 ISO 8573.1 Solid < 0,1 µm Dew point < +3°C Oil < 0,01 mg/m ³
Pressure:	6 - 10 bar (g)
Temperature:	+5..... +45°C

⁽²⁾ Dew point at atmospheric pressure.

⁽³⁾ Necessary for guarantee performance of the nitrogen generator.

Nitrogen Specifications

Outlet pressure:	0-9 bar(g)
Dew point: ⁽²⁾	< 40°C
Nitrogen process tank: ⁽³⁾	270 lt

Power Requirements

Power Supply:	230 V / 50 - 60 Hz
Power Consumption:	max. 0,5 kW



Dimensions & Weight

M:	440 mm
L:	900 mm
P:	1150 mm
H:	2070 mm
Weight:	410 kg

Connections

Air inlet:	G1"
N ₂ outlet:	G1"
N ₂ to process tank:	G1"
N ₂ from process tank:	G1"
O ₂ enriched air outlet:	G3"

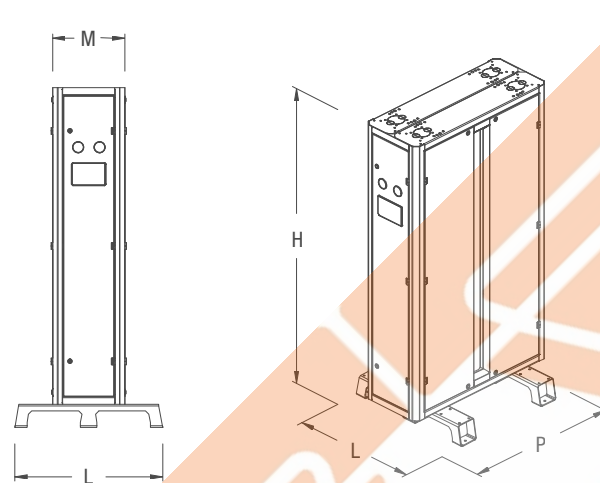

STANDARD EQUIPMENT AND OPTIONS

- = standard equipment
- = option

Control panel

4 line display	●
----------------	---

Purity monitoring and control

O ₂ Electrochemical Sensor 0-25 %	○
O ₂ Zirconium Sensor 0-25 %	○
O ₂ Zirconium Sensor 10-1000 ppm	○
Dew point sensor with indication on display	○
Flow meter with indication on display	○

Valves and accessories

Back pressure control valve kit	○
Compressed air pressure sensor	●
Nitrogen buffer pressure sensor	●
Process tank pressure sensor	●
Exhaust silencer	●
Super exhaust silencer extern mounted	○

Logging and data handling

Analog output 4-20mA (O ₂ level)	●
Modbus RTU	●
Modbus RS485/USB serial converter	○
Profibus connection convert	○
Canbus connection convert	○
Ewon (webserver + sms alarm + data logging)	○
Digital remote control	●
Extern alarm digital input	●

Necessary accessory

Process tank with all accessories	270 lt
-----------------------------------	--------



MODULAR PSA NITROGEN GENERATORS

NIMOS S4

Performance at inlet pressure: **7,5 bar (g)**

	LP					HP				
Nitrogen purity rate	95 %	97 %	98 %	99 %	99,5 %	99,9 %	99,95 %	99,99 %	99,995 %	99,999 %
Residual oxygen	5 %	3 %	2 %	1 %	0,5 %	0,1 %	500 PPM	100 PPM	50 PPM	10 PPM
Flow m³/h ⁽¹⁾ FND	57,7	46,1	39,6	31,6	25,8	16,9	14,2	9,5	8,0	5,4
Feed Air m³/h FAD	116,9	101,8	93,4	83,5	76,7	65,8	62,2	55,4	53,4	52,7

(1) Flow rates at standard atmospheric conditions (20°C/1000 mbar/0% RH) - Nitrogen outlet pressure 6bar(g) - Performance data ± 5%

Performance at inlet pressure: **9,5 bar (g)**

	LP					HP				
Nitrogen purity rate	95 %	97 %	98 %	99 %	99,5 %	99,9 %	99,95 %	99,99 %	99,995 %	99,999 %
Residual oxygen	5 %	3 %	2 %	1 %	0,5 %	0,1 %	500 PPM	100 PPM	50 PPM	10 PPM
Flow m³/h ⁽¹⁾ FND	69,2	55,3	47,5	37,9	31,0	20,3	17,1	11,4	9,6	6,5
Feed Air m³/h FAD	142,4	124,0	113,8	101,7	93,4	79,9	75,2	65,8	62,1	54,4

(1) Flow rates at standard atmospheric conditions (20°C/1000 mbar/0% RH) - Nitrogen outlet pressure 6bar(g) - Performance data ± 5%

Feed Air Requirements

Quality:	Class 1-4-1 ISO 8573.1 Solid < 0,1 µm Dew point < +3°C Oil < 0,01 mg/m ³
Pressure:	6 - 10 bar (g)
Temperature:	+5..... +45°C

⁽²⁾ Dew point at atmospheric pressure.

⁽³⁾ Necessary for guarantee performance of the nitrogen generator.

Nitrogen Specifications

Outlet pressure:	0-9 bar(g)
Dew point: ⁽²⁾	< 40°C
Nitrogen process tank: ⁽³⁾	270 lt

Power Requirements

Power Supply:	230 V / 50 - 60 Hz
Power Consumption:	max. 0,5 kW



Dimensions & Weight

M:	440 mm
L:	900 mm
P:	1150 mm
H:	2070 mm
Weight:	470 kg

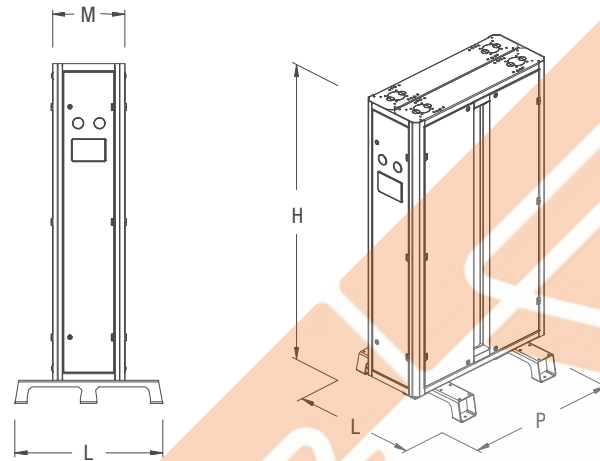

Connections

Air inlet:	G1"
N ₂ outlet:	G1"
N ₂ to process tank:	G1"
N ₂ from process tank:	G1"
O ₂ enriched air outlet:	G3"

STANDARD EQUIPMENT AND OPTIONS

- = standard equipment
- = option

Control panel

4 line display	●
----------------	---

Purity monitoring and control

O ₂ Electrochemical Sensor 0-25 %	○
O ₂ Zirconium Sensor 0-25 %	○
O ₂ Zirconium Sensor 10-1000 ppm	○
Dew point sensor with indication on display	○
Flow meter with indication on display	○

Valves and accessories

Back pressure control valve kit	○
Compressed air pressure sensor	●
Nitrogen buffer pressure sensor	●
Process tank pressure sensor	●
Exhaust silencer	●
Super exhaust silencer extern mounted	○

Logging and data handling

Analog output 4-20mA (O ₂ level)	●
Modbus RTU	●
Modbus RS485/USB serial converter	○
Profibus connection convert	○
Canbus connection convert	○
Ewon (webservice + sms alarm + data logging)	○
Digital remote control	●
Extern alarm digital input	●

Necessary accessory

Process tank with all accessories	270 lt
-----------------------------------	--------

MODULAR PSA NITROGEN GENERATORS

NIMOS S5

Performance at inlet pressure: **7,5 bar (g)**

	LP					HP				
Nitrogen purity rate	95 %	97 %	98 %	99 %	99,5 %	99,9 %	99,95 %	99,99 %	99,995 %	99,999 %
Residual oxygen	5 %	3 %	2 %	1 %	0,5 %	0,1 %	500 PPM	100 PPM	50 PPM	10 PPM
Flow m³/h ⁽¹⁾ FND	72,2	57,8	49,6	39,5	32,4	21,2	17,8	11,9	10,1	6,7
Feed Air m³/h FAD	146,1	127,2	116,8	104,4	95,9	82,3	77,7	69,2	66,7	65,9

(1) Flow rates at standard atmospheric conditions (20°C/1000 mbar/0% RH) - Nitrogen outlet pressure 6bar(g) - Performance data ± 5%

Performance at inlet pressure: **9,5 bar (g)**

	LP					HP				
Nitrogen purity rate	95 %	97 %	98 %	99 %	99,5 %	99,9 %	99,95 %	99,99 %	99,995 %	99,999 %
Residual oxygen	5 %	3 %	2 %	1 %	0,5 %	0,1 %	500 PPM	100 PPM	50 PPM	10 PPM
Flow m³/h ⁽¹⁾ FND	86,6	69,3	59,5	47,4	38,8	25,4	21,4	14,3	12,1	8,1
Feed Air m³/h FAD	178,1	155,0	142,3	127,2	116,8	100,3	94,7	84,4	81,3	80,2

(1) Flow rates at standard atmospheric conditions (20°C/1000 mbar/0% RH) - Nitrogen outlet pressure 6bar(g) - Performance data ± 5%

Feed Air Requirements

Quality:	Class 1-4-1 ISO 8573.1 Solid < 0,1 µm Dew point < +3°C Oil < 0,01 mg/m ³
Pressure:	6 - 10 bar (g)
Temperature:	+5..... +45°C

⁽²⁾ Dew point at atmospheric pressure.

⁽³⁾ Necessary for guarantee performance of the nitrogen generator.

Nitrogen Specifications

Outlet pressure:	0-9 bar(g)
Dew point: ⁽²⁾	< 40°C
Nitrogen process tank: ⁽³⁾	500 lt

Power Requirements

Power Supply:	230 V / 50 - 60 Hz
Power Consumption:	max. 0,5 kW



Dimensions & Weight

M:	440 mm
L:	900 mm
P:	1550 mm
H:	2070 mm
Weight:	530 kg

Connections

Air inlet:	G1"
N ₂ outlet:	G1"
N ₂ to process tank:	G1"
N ₂ from process tank:	G1"
O ₂ enriched air outlet:	G3"

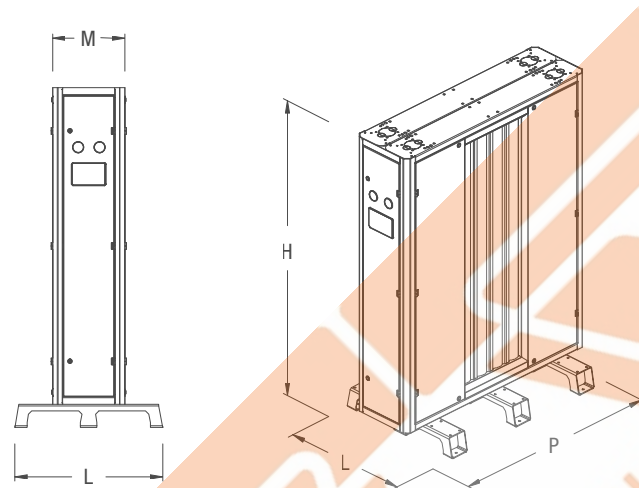

STANDARD EQUIPMENT AND OPTIONS

- = standard equipment
- = option

Control panel

4 line display	●
----------------	---

Purity monitoring and control

O ₂ Electrochemical Sensor 0-25 %	○
O ₂ Zirconium Sensor 0-25 %	○
O ₂ Zirconium Sensor 10-1000 ppm	○
Dew point sensor with indication on display	○
Flow meter with indication on display	○

Valves and accessories

Back pressure control valve kit	○
Compressed air pressure sensor	●
Nitrogen buffer pressure sensor	●
Process tank pressure sensor	●
Exhaust silencer	●
Super exhaust silencer extern mounted	○

Logging and data handling

Analog output 4-20mA (O ₂ level)	●
Modbus RTU	●
Modbus RS485/USB serial converter	○
Profibus connection convert	○
Canbus connection convert	○
Ewon (webservice + sms alarm + data logging)	○
Digital remote control	●
Extern alarm digital input	●

Necessary accessory

Process tank with all accessories	500 lt
-----------------------------------	--------



MODULAR PSA NITROGEN GENERATORS

NIMOS S6

Performance at inlet pressure: **7,5 bar (g)**

	LP					HP				
Nitrogen purity rate	95 %	97 %	98 %	99 %	99,5 %	99,9 %	99,95 %	99,99 %	99,995 %	99,999 %
Residual oxygen	5 %	3 %	2 %	1 %	0,5 %	0,1 %	500 PPM	100 PPM	50 PPM	10 PPM
Flow m³/h ⁽¹⁾ FND	86,9	69,5	59,6	47,5	38,9	25,5	21,4	14,4	12,1	8,1
Feed Air m³/h FAD	175,4	152,6	140,1	125,3	115,1	98,7	93,3	83,1	80,0	79,0

(1) Flow rates at standard atmospheric conditions (20°C/1000 mbar/0% RH) - Nitrogen outlet pressure 6bar(g) - Performance data ± 5%

Performance at inlet pressure: **9,5 bar (g)**

	LP					HP				
Nitrogen purity rate	95 %	97 %	98 %	99 %	99,5 %	99,9 %	99,95 %	99,99 %	99,995 %	99,999 %
Residual oxygen	5 %	3 %	2 %	1 %	0,5 %	0,1 %	500 PPM	100 PPM	50 PPM	10 PPM
Flow m³/h ⁽¹⁾ FND	104,2	83,3	71,5	57,0	46,7	30,6	25,7	17,2	14,5	9,7
Feed Air m³/h FAD	213,7	186,0	170,8	152,7	140,2	120,3	113,6	101,2	97,5	96,3

(1) Flow rates at standard atmospheric conditions (20°C/1000 mbar/0% RH) - Nitrogen outlet pressure 6bar(g) - Performance data ± 5%

Feed Air Requirements

Quality:	Class 1-4-1 ISO 8573.1 Solid < 0,1 µm Dew point < +3°C Oil < 0,01 mg/m ³
Pressure:	6 - 10 bar (g)
Temperature:	+5..... +45°C

⁽²⁾ Dew point at atmospheric pressure.

⁽³⁾ Necessary for guarantee performance of the nitrogen generator.

Nitrogen Specifications

Outlet pressure:	0-9 bar(g)
Dew point: ⁽²⁾	< 40°C
Nitrogen process tank: ⁽³⁾	500 lt

Power Requirements

Power Supply:	230 V / 50 - 60 Hz
Power Consumption:	max. 0,5 kW



Dimensions & Weight

M:	440 mm
L:	900 mm
P:	1550 mm
H:	2070 mm
Weight:	600 kg

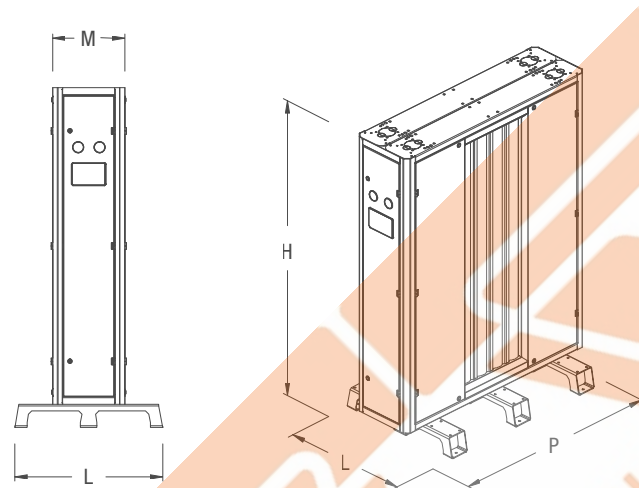

Connections

Air inlet:	G1"
N ₂ outlet:	G1"
N ₂ to process tank:	G1"
N ₂ from process tank:	G1"
O ₂ enriched air outlet:	G3"

STANDARD EQUIPMENT AND OPTIONS

- = standard equipment
- = option

Control panel

4 line display	●
----------------	---

Purity monitoring and control

O ₂ Electrochemical Sensor 0-25 %	○
O ₂ Zirconium Sensor 0-25 %	○
O ₂ Zirconium Sensor 10-1000 ppm	○
Dew point sensor with indication on display	○
Flow meter with indication on display	○

Valves and accessories

Back pressure control valve kit	○
Compressed air pressure sensor	●
Nitrogen buffer pressure sensor	●
Process tank pressure sensor	●
Exhaust silencer	●
Super exhaust silencer extern mounted	○

Logging and data handling

Analog output 4-20mA (O ₂ level)	●
Modbus RTU	●
Modbus RS485/USB serial converter	○
Profibus connection convert	○
Canbus connection convert	○
Ewon (webservice + sms alarm + data logging)	○
Digital remote control	●
Extern alarm digital input	●

Necessary accessory

Process tank with all accessories	500 lt
-----------------------------------	--------



MODULAR PSA NITROGEN GENERATORS

NIMOS S7

Performance at inlet pressure: **7,5 bar (g)**

	LP					HP				
Nitrogen purity rate	95 %	97 %	98 %	99 %	99,5 %	99,9 %	99,95 %	99,99 %	99,995 %	99,999 %
Residual oxygen	5 %	3 %	2 %	1 %	0,5 %	0,1 %	500 PPM	100 PPM	50 PPM	10 PPM
Flow m³/h ⁽¹⁾ FND	101,5	81,2	69,7	55,6	45,5	29,8	25,1	16,8	14,1	9,5
Feed Air m³/h FAD	204,6	178,1	163,5	146,2	134,3	115,2	108,8	96,9	93,4	92,2

(1) Flow rates at standard atmospheric conditions (20°C/1000 mbar/0% RH) - Nitrogen outlet pressure 6bar(g) - Performance data ± 5%

Performance at inlet pressure: **9,5 bar (g)**

	LP					HP				
Nitrogen purity rate	95 %	97 %	98 %	99 %	99,5 %	99,9 %	99,95 %	99,99 %	99,995 %	99,999 %
Residual oxygen	5 %	3 %	2 %	1 %	0,5 %	0,1 %	500 PPM	100 PPM	50 PPM	10 PPM
Flow m³/h ⁽¹⁾ FND	121,8	97,4	83,6	66,7	54,6	35,8	30,0	20,1	16,9	11,4
Feed Air m³/h FAD	249,3	217,0	199,2	178,1	163,6	140,4	132,6	118,1	113,8	112,3

(1) Flow rates at standard atmospheric conditions (20°C/1000 mbar/0% RH) - Nitrogen outlet pressure 6bar(g) - Performance data ± 5%

Feed Air Requirements

Quality:	Class 1-4-1 ISO 8573.1 Solid < 0,1 µm Dew point < +3°C Oil < 0,01 mg/m ³
Pressure:	6 - 10 bar (g)
Temperature:	+5..... +45°C

⁽²⁾ Dew point at atmospheric pressure.

⁽³⁾ Necessary for guarantee performance of the nitrogen generator.

Nitrogen Specifications

Outlet pressure:	0-9 bar(g)
Dew point: ⁽²⁾	< 40°C
Nitrogen process tank: ⁽³⁾	500 lt

Power Requirements

Power Supply:	230 V / 50 - 60 Hz
Power Consumption:	max. 0,5 kW



Dimensions & Weight

M:	440 mm
L:	900 mm
P:	1550 mm
H:	2070 mm
Weight:	670 kg

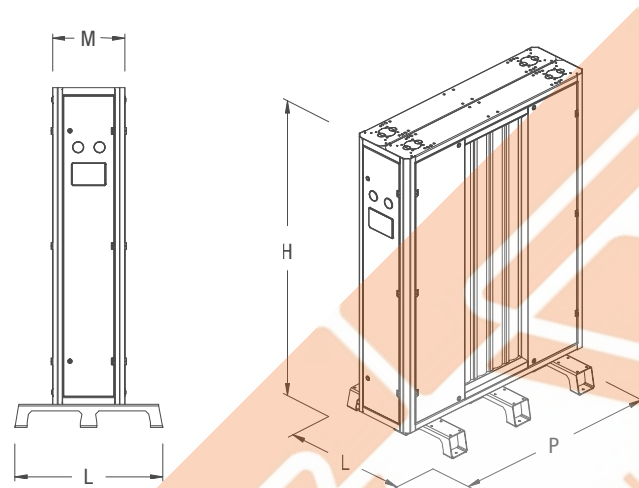

Connections

Air inlet:	G1"
N ₂ outlet:	G1"
N ₂ to process tank:	G1"
N ₂ from process tank:	G1"
O ₂ enriched air outlet:	G3"

STANDARD EQUIPMENT AND OPTIONS

- = standard equipment
- = option

Control panel

4 line display	●
----------------	---

Purity monitoring and control

O ₂ Electrochemical Sensor 0-25 %	○
O ₂ Zirconium Sensor 0-25 %	○
O ₂ Zirconium Sensor 10-1000 ppm	○
Dew point sensor with indication on display	○
Flow meter with indication on display	○

Valves and accessories

Back pressure control valve kit	○
Compressed air pressure sensor	●
Nitrogen buffer pressure sensor	●
Process tank pressure sensor	●
Exhaust silencer	●
Super exhaust silencer extern mounted	○

Logging and data handling

Analog output 4-20mA (O ₂ level)	●
Modbus RTU	●
Modbus RS485/USB serial converter	○
Profibus connection convert	○
Canbus connection convert	○
Ewon (webserver + sms alarm + data logging)	○
Digital remote control	●
Extern alarm digital input	●

Necessary accessory

Process tank with all accessories	500 lt
-----------------------------------	--------



MODULAR PSA NITROGEN GENERATORS

NIMOS S8

Performance at inlet pressure: **7,5 bar (g)**

	LP					HP				
Nitrogen purity rate	95 %	97 %	98 %	99 %	99,5 %	99,9 %	99,95 %	99,99 %	99,995 %	99,999 %
Residual oxygen	5 %	3 %	2 %	1 %	0,5 %	0,1 %	500 PPM	100 PPM	50 PPM	10 PPM
Flow m³/h ⁽¹⁾ FND	116,3	93,0	79,8	63,7	52,1	34,2	28,7	19,2	16,2	10,9
Feed Air m³/h FAD	233,8	203,5	186,9	167,1	153,4	131,7	124,4	110,8	106,7	105,4

(1) Flow rates at standard atmospheric conditions (20°C/1000 mbar/0% RH) - Nitrogen outlet pressure 6bar(g) - Performance data ± 5%

Performance at inlet pressure: **9,5 bar (g)**

	LP					HP				
Nitrogen purity rate	95 %	97 %	98 %	99 %	99,5 %	99,9 %	99,95 %	99,99 %	99,995 %	99,999 %
Residual oxygen	5 %	3 %	2 %	1 %	0,5 %	0,1 %	500 PPM	100 PPM	50 PPM	10 PPM
Flow m³/h ⁽¹⁾ FND	139,4	111,5	95,8	76,3	62,5	41,0	34,4	23,0	19,4	13,0
Feed Air m³/h FAD	284,9	248,0	227,7	203,6	187,0	160,4	151,5	135,0	130,0	128,4

(1) Flow rates at standard atmospheric conditions (20°C/1000 mbar/0% RH) - Nitrogen outlet pressure 6bar(g) - Performance data ± 5%

Feed Air Requirements

Quality:	Class 1-4-1 ISO 8573.1 Solid < 0,1 µm Dew point < +3°C Oil < 0,01 mg/m ³
Pressure:	6 - 10 bar (g)
Temperature:	+5..... +45°C

⁽²⁾ Dew point at atmospheric pressure.

⁽³⁾ Necessary for guarantee performance of the nitrogen generator.

Nitrogen Specifications

Outlet pressure:	0-9 bar(g)
Dew point: ⁽²⁾	< 40°C
Nitrogen process tank: ⁽³⁾	500 lt

Power Requirements

Power Supply:	230 V / 50 - 60 Hz
Power Consumption:	max. 0,5 kW



Dimensions & Weight

M:	440 mm
L:	900 mm
P:	1950 mm
H:	2070 mm
Weight:	830 kg

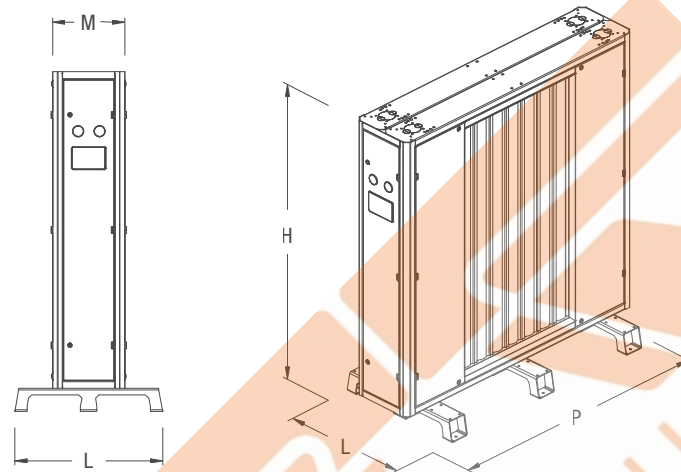

Connections

Air inlet:	G1"
N ₂ outlet:	G1"
N ₂ to process tank:	G1"
N ₂ from process tank:	G1"
O ₂ enriched air outlet:	G3"

STANDARD EQUIPMENT AND OPTIONS

- = standard equipment
- = option

Control panel	
4 line display	●
Purity monitoring and control	
O ₂ Electrochemical Sensor 0-25 %	○
O ₂ Zirconium Sensor 0-25 %	○
O ₂ Zirconium Sensor 10-1000 ppm	○
Dew point sensor with indication on display	○
Flow meter with indication on display	○
Valves and accessories	
Back pressure control valve kit	○
Compressed air pressure sensor	●
Nitrogen buffer pressure sensor	●
Process tank pressure sensor	●
Exhaust silencer	●
Super exhaust silencer extern mounted	○

Logging and data handling	
Analog output 4-20mA (O ₂ level)	●
Modbus RTU	●
Modbus RS485/USB serial converter	○
Profibus connection convert	○
Canbus connection convert	○
Ewon (webserver + sms alarm + data logging)	○
Digital remote control	●
Extern alarm digital input	●

Necessary accessory	
Process tank with all accessories	500 lt

MODULAR PSA NITROGEN GENERATORS

NIMOS S9

Performance at inlet pressure: **7,5 bar (g)**

	LP					HP				
Nitrogen purity rate	95 %	97 %	98 %	99 %	99,5 %	99,9 %	99,95 %	99,99 %	99,995 %	99,999 %
Residual oxygen	5 %	3 %	2 %	1 %	0,5 %	0,1 %	500 PPM	100 PPM	50 PPM	10 PPM
Flow m³/h ⁽¹⁾ FND	131,1	104,8	90,0	71,8	58,7	38,5	32,3	21,7	18,2	12,2
Feed Air m³/h FAD	263,1	229,0	210,2	188,0	172,6	148,1	139,9	124,6	120,1	118,5

(1) Flow rates at standard atmospheric conditions (20°C/1000 mbar/0% RH) - Nitrogen outlet pressure 6bar(g) - Performance data ± 5%

Performance at inlet pressure: **9,5 bar (g)**

	LP					HP				
Nitrogen purity rate	95 %	97 %	98 %	99 %	99,5 %	99,9 %	99,95 %	99,99 %	99,995 %	99,999 %
Residual oxygen	5 %	3 %	2 %	1 %	0,5 %	0,1 %	500 PPM	100 PPM	50 PPM	10 PPM
Flow m³/h ⁽¹⁾ FND	157,2	125,7	107,9	86,0	70,4	46,2	38,8	26,0	21,9	14,7
Feed Air m³/h FAD	320,5	279,0	256,1	229,0	210,3	180,5	170,5	151,9	146,3	144,4

(1) Flow rates at standard atmospheric conditions (20°C/1000 mbar/0% RH) - Nitrogen outlet pressure 6bar(g) - Performance data ± 5%

Feed Air Requirements

Quality:	Class 1-4-1 ISO 8573.1 Solid < 0,1 µm Dew point < +3°C Oil < 0,01 mg/m ³
Pressure:	6 - 10 bar (g)
Temperature:	+5..... +45°C

⁽²⁾ Dew point at atmospheric pressure.

⁽³⁾ Necessary for guarantee performance of the nitrogen generator.

Nitrogen Specifications

Outlet pressure:	0-9 bar(g)
Dew point: ⁽²⁾	< 40°C
Nitrogen process tank: ⁽³⁾	500 lt

Power Requirements

Power Supply:	230 V / 50 - 60 Hz
Power Consumption:	max. 0,5 kW



Dimensions & Weight

M:	440 mm
L:	900 mm
P:	1950 mm
H:	2070 mm
Weight:	900 kg

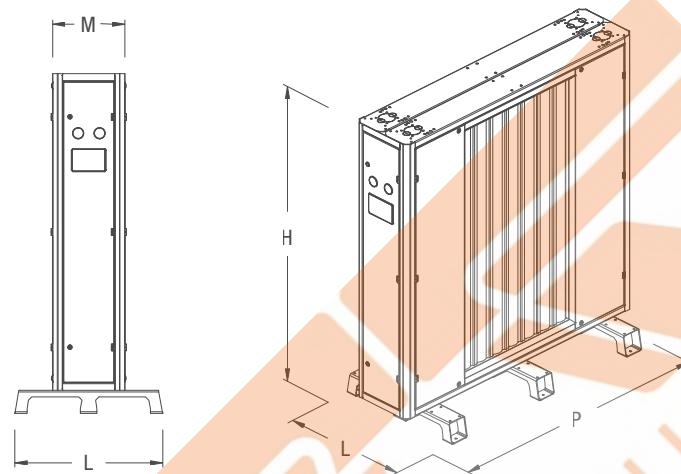

Connections

Air inlet:	G1"
N ₂ outlet:	G1"
N ₂ to process tank:	G1"
N ₂ from process tank:	G1"
O ₂ enriched air outlet:	G3"

STANDARD EQUIPMENT AND OPTIONS

- = standard equipment
- = option

Control panel	
4 line display	●
Purity monitoring and control	
O ₂ Electrochemical Sensor 0-25 %	○
O ₂ Zirconium Sensor 0-25 %	○
O ₂ Zirconium Sensor 10-1000 ppm	○
Dew point sensor with indication on display	○
Flow meter with indication on display	○
Valves and accessories	
Back pressure control valve kit	○
Compressed air pressure sensor	●
Nitrogen buffer pressure sensor	●
Process tank pressure sensor	●
Exhaust silencer	●
Super exhaust silencer extern mounted	○

Logging and data handling	
Analog output 4-20mA (O ₂ level)	●
Modbus RTU	●
Modbus RS485/USB serial converter	○
Profibus connection convert	○
Canbus connection convert	○
Ewon (webservice + sms alarm + data logging)	○
Digital remote control	●
Extern alarm digital input	●

Necessary accessory	
Process tank with all accessories	500 lt

MODULAR PSA NITROGEN GENERATORS

NIMOS S10

Performance at inlet pressure: **7,5 bar (g)**

	LP					HP				
Nitrogen purity rate	95 %	97 %	98 %	99 %	99,5 %	99,9 %	99,95 %	99,99 %	99,995 %	99,999 %
Residual oxygen	5 %	3 %	2 %	1 %	0,5 %	0,1 %	500 PPM	100 PPM	50 PPM	10 PPM
Flow m³/h ⁽¹⁾ FND	145,9	116,7	100,2	79,9	65,4	42,9	36,0	24,1	20,3	13,6
Feed Air m³/h FAD	292,3	254,4	233,6	208,9	191,8	164,6	155,5	138,5	133,4	131,7

(1) Flow rates at standard atmospheric conditions (20°C/1000 mbar/0% RH) - Nitrogen outlet pressure 6bar(g) - Performance data ± 5%

Performance at inlet pressure: **9,5 bar (g)**

	LP					HP				
Nitrogen purity rate	95 %	97 %	98 %	99 %	99,5 %	99,9 %	99,95 %	99,99 %	99,995 %	99,999 %
Residual oxygen	5 %	3 %	2 %	1 %	0,5 %	0,1 %	500 PPM	100 PPM	50 PPM	10 PPM
Flow m³/h ⁽¹⁾ FND	175,0	140,0	120,2	95,8	78,4	51,4	43,2	28,9	24,3	16,3
Feed Air m³/h FAD	356,1	310,0	284,6	254,5	233,7	200,5	189,4	168,7	162,6	160,5

(1) Flow rates at standard atmospheric conditions (20°C/1000 mbar/0% RH) - Nitrogen outlet pressure 6bar(g) - Performance data ± 5%

Feed Air Requirements

Quality:	Class 1-4-1 ISO 8573.1 Solid < 0,1 µm Dew point < +3°C Oil < 0,01 mg/m ³
Pressure:	6 - 10 bar (g)
Temperature:	+5..... +45°C

⁽²⁾ Dew point at atmospheric pressure.

⁽³⁾ Necessary for guarantee performance of the nitrogen generator.

Nitrogen Specifications

Outlet pressure:	0-9 bar(g)
Dew point: ⁽³⁾	< 40°C
Nitrogen process tank: ⁽⁴⁾	500 lt

Power Requirements

Power Supply:	230 V / 50 - 60 Hz
Power Consumption:	max. 0,5 kW



Dimensions & Weight

M:	440 mm
L:	900 mm
P:	1950 mm
H:	2070 mm
Weight:	960 kg

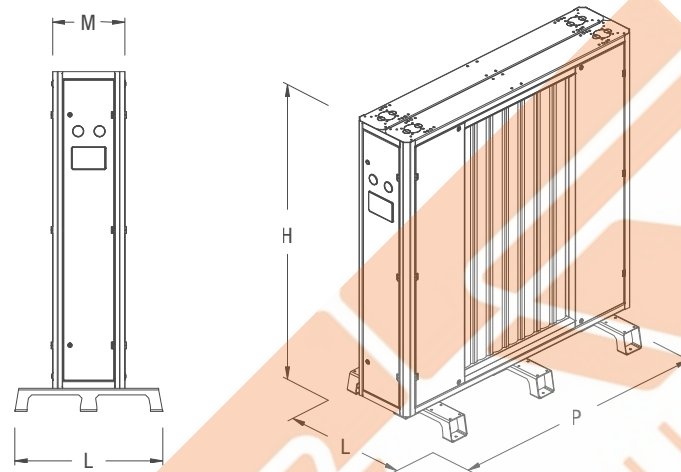

Connections

Air inlet:	G1"
N ₂ outlet:	G1"
N ₂ to process tank:	G1"
N ₂ from process tank:	G1"
O ₂ enriched air outlet:	G3"

STANDARD EQUIPMENT AND OPTIONS

- = standard equipment
- = option

Control panel

4 line display	●
----------------	---

Purity monitoring and control

O ₂ Electrochemical Sensor 0-25 %	○
O ₂ Zirconium Sensor 0-25 %	○
O ₂ Zirconium Sensor 10-1000 ppm	○
Dew point sensor with indication on display	○
Flow meter with indication on display	○

Valves and accessories

Back pressure control valve kit	○
Compressed air pressure sensor	●
Nitrogen buffer pressure sensor	●
Process tank pressure sensor	●
Exhaust silencer	●
Super exhaust silencer extern mounted	○

Logging and data handling

Analog output 4-20mA (O ₂ level)	●
Modbus RTU	●
Modbus RS485/USB serial converter	○
Profibus connection convert	○
Canbus connection convert	○
Ewon (webservice + sms alarm + data logging)	○
Digital remote control	●
Extern alarm digital input	●

Necessary accessory

Process tank with all accessories	500 lt
-----------------------------------	--------

